

NEXUS

NEW TIMES MAGAZINE

Volume 5, Number 6 OCTOBER - NOVEMBER 1998

PO Box 30, Mapleton Qld 4560, Australia

CONTENTS

LETTERS TO THE EDITOR.....4	NEW SWIRLED ORDER: CROP CIRCLES OF '98.....59
GLOBAL NEWS.....6	<i>By Marcus Allen. A variety of inventive and strangely familiar designs have cropped up in the fields of England this season, but researchers are yet to unravel the mysteries of their origins.</i>
<i>A round-up of the news you may have missed. This issue features a list of 'suspicious' deaths of people who allegedly held incriminating evidence of illegal activities surrounding Bill Clinton.</i>	THE TWILIGHT ZONE.....67
MILITARY MIND-CONTROL WEAPONS.....13	<i>Strange tales from around/within/beyond the world. This issue includes an item on Dr Robert Jacobs who admits the USAF has high-speed film footage of UFOs; the latest on the Vatican priest who believes in ETs; and news on the 'Scott Stones' at Bimini.</i>
<i>By Judy Wall. The technology to control minds and emotions has been a closely guarded secret of the military-industrial complex for many years. It was used with surprising effect in the Gulf War.</i>	ALIEN HEALINGS: THE MEDICAL EVIDENCE71
OSTEOPOROSIS: THE BONES OF CONTENTION....21	<i>By Preston Dennett. Credible medical evidence has been amassed which supports numerous claims of people being miraculously healed by benevolent aliens during close encounters.</i>
<i>By Sherrill Sellman. Pharmaceutical companies have manufactured the 'bone loss' scare to create a market for products that promise women good health but, in reality, severely compromise it.</i>	REVIEWS—Books.....77
SPOOKS, WHISTLEBLOWERS & FALL GUYS.....29	<i>"Positively False: ...Myths around HIV and AIDS" by Joan Shenton</i>
<i>By Uri Dowbenko. In concluding this interview, whistleblower Rodney Stich reveals incriminating evidence from former US intelligence agents on official corruption and on the demise of TWA 800.</i>	<i>"Conversing with the Future: Visions of...2020" by Jenna Catherine</i>
STAR FIRE: THE GOLD OF THE GODS—Part 1.....35	<i>"HAARP: The Ultimate Weapon of the Conspiracy" by Jerry Smith</i>
<i>By Sir Laurence Gardner. The legendary Anunnaki 'gods' reputedly established the Grail bloodline in ancient Sumer at least 6,000 years ago and sustained it with a powerful alchemical substance.</i>	<i>"Vital Signs" by Andy Thomas</i>
HANS COLER'S FREE-ENERGY GENERATORS.....43	<i>"Forbidden Archeology's Impact" by Michael A. Cremo</i>
<i>By Robert Nelson. German inventor Hans Coler's magnet-based power-generating devices attracted British military/intelligence interest at the end of WWII, but are long overdue for serious reappraisal.</i>	<i>"Maya Cosmogogenesis 2012" by John Major Jenkins</i>
NEW SCIENCE NEWS.....51	<i>"My Search for Traces of God" by Philip S. Callahan, PhD</i>
<i>Interesting news/views from the underground science network. Here we publish NuTech 2000's update on the phenomenal Joe fuel cell; and details of a system that converts EM radiation to electricity.</i>	<i>"The Giza Power Plant" by Christopher P. Dunn</i>
	<i>"The Mars Mystery" by G. Hancock, R. Bauval and J. Grigsby</i>
	<i>"How Prayer Heals: A Scientific Approach" by Walter Weston</i>
	<i>"The FBI Files: ...UFO Top Secrets Exposed" by Nicholas Redfern</i>
	<i>"The Phoenix Solution" by Alan F. Alford</i>
	<i>"The Asthma Breakthrough" by Henry Osiecki, BSc</i>
	<i>"Secret Cities of Old South America" by Harold T. Wilkins</i>
	<i>"World Ages" by Björn H. Hammarskog</i>
	REVIEWS—Video.....84
	<i>"Prophecy and Prediction: Threat or Warning?" by Film Montage</i>
	REVIEWS—CD-ROM.....84
	<i>"The UFO Anthology: Volume One" by Dreamland Interactive</i>
	REVIEWS—Audio.....85
	<i>"Women of Spirit" by Various Artists</i>
	<i>"Enter the Heart" by Estéban</i>
	<i>"The Journey" by Maryam Mursal</i>
	<i>"Silencium: Songs of the Spirit" by The Silencium Ensemble</i>
	<i>"Pilgrimage" by The New London Consort</i>
	NEXUS BOOKS, SUBS, ADS & VIDEOS.....97

NEXUS MAGAZINE

Volume 5, Number 6

OCTOBER-NOVEMBER 1998

PUBLISHED BY

NEXUS Magazine Pty Ltd, ACN #003 611 434

EDITOR

Duncan M. Roads

CO-EDITOR

Catherine Simons

ASSISTANT EDITOR/SUB-EDITOR

Ruth Parnell

EDITORS' ASSISTANT

Richard Giles

OFFICE ADMINISTRATOR

Janine Carmichael

CONTRIBUTORS THIS ISSUE

Judy Wall; Uri Dowbenko; Sherrill Sellman;
Sir Laurence Gardner, Kt St Gm., KCD, Kt St A.,
Robert Nelson; Ian/NuTech 2000;
Marcus Allen; Preston Dennett

LAYOUT & DESIGN

Duncan M. Roads

CARTOONS

Phil Somerville

COVER GRAPHIC

John Cook, jscook@ozemail.com.au

PRINTING

Warwick Daily News, Queensland, Australia

AUSTRALIAN DISTRIBUTION

Newsagents Direct Distribution

HEAD OFFICE - All Correspondence

PO Box 30, Mapleton, Qld 4560, Australia.

Ph: (07) 5442 9280; Fax: (07) 5442 9381

E-mail address: nexus@peg.apc.org

Web page: <http://www.peg.apc.org/~nexus/>

NEW ZEALAND OFFICE - PO Box 226, Russell,

Bay of Islands. Ph: +64 (0)9 403 8193;

Fax: +64 (0)9 403 8196;

E-mail address: nexusnz@xtra.co.nz

USA OFFICE - PO Box 177, Kempton, IL 60946-

0177. Ph: (815) 253 6464; Fax: (815) 253 6454

E-mail address: nexususa@earthlink.net

UK OFFICE - 55 Queens Rd, East Grinstead, West

Sussex, RH19 1BG. Ph: +44 (0)1342 322854;

Fax: +44 (0)1342 324574;

E-mail address: nexus@ukoffice.u-net.com

EUROPE OFFICE - PO Box 372, 8250 AJ Dronten,

The Netherlands. Ph: +31 (0)321 380558;

Fax: +31 (0)321 318892;

E-mail address: frontier@xs4all.nl

STATEMENT OF PURPOSE

NEXUS recognises that humanity is undergoing a massive transformation. With this in mind, NEXUS seeks to provide 'hard-to-get' information so as to assist people through these changes. NEXUS is not linked to any religious, philosophical or political ideology or organisation.

PERMISSION-TO-REPRODUCE POLICY

While reproduction and dissemination of the information in NEXUS is actively encouraged, anyone caught making a buck out of it, without our express permission, will be in trouble when we catch them!

Editorial

I love springtime—the promise of new things, the gentle warmth, the brilliant green of the grass, the smell of the flowers (well, it is the southern hemisphere here), another lunar eclipse (tonight)—and a new-season NEXUS....

It feels as if a lot has happened since the last time I sat here, late at night, writing my editorial and wondering if I'm going to make it to bed before breakfast.

The big thing for us, of course, was our annual NEXUS Conference in Sydney in late July. Inspiring speakers and a warm, receptive audience meant a good time was had by all. In fact, it was so good, I think we'll do it again next year! Mark your diaries now: 22–23 May 1999, in Sydney; speaker details early next year.

That is, if Sydney is still there! I refer to my lingering concerns about the large number of people having dreams of a tidal wave hitting the east coast of Australia, Sydney in particular, some time during the next few years. I have had waves (pardon the pun) of letters and phone calls about this before, but nothing like this. You can almost feel it in the air. To top it off, even more recently a number of TV films/documentaries have been broadcast on the subject of tidal waves hitting the Australian east coast in the past and the future. These have triggered even more letters and calls from people. One lady had even dreamed she was standing on Bondi Beach when the ocean suddenly started retreating way out offshore, then reared back in as a huge wave. She had no idea that this is often what happens as a tsunami approaches a shallow coastal shelf. First the waters seem to drain out to sea, then the tsunami comes crashing in.

Oh well, we have survived numerous prophecies of destruction that should have been fulfilled by now, but still listen to your intuition and instinct. These are certainly times of increasing tectonic plate activity, and I've heard that an underwater 'hot spot' has been identified a few hundred miles off the NSW coast.

But back to the issue at hand. This one sees the start of Sir Laurence Gardner's three-part series on *The Gold of the Gods*, based on his awesome presentation at the recent NEXUS conference. If you are fascinated by the white powder gold phenomenon, you'll really appreciate this series.

Sherrill Sellman (author of *Hormone Heresy*) phoned me a few weeks ago, all fired up about National Bone Week or something like that—you know the sort: "Drink three cups of milk per day, take HRT and you'll never get osteoporosis". Her outrage rubbed off on me, so I asked (as usual) for an urgent 4,500-word article and got pages more. Luckily for you (and Sherrill), I knew that would happen. End result: a bone-chilling exposé that's a must-read for both men and women.

We have a round-up of the amazing crop circle formations and related goings-on in England this year; but if you want to see the full range of designs (and in colour), jump onto the Internet and visit the Crop Circle Connector website.

A few people filling in our Internet visitor's survey have commented that they find the CIA drugs articles boring. I have deliberately kept a number of these running because not enough is being done to expose these scandals and because most would prefer them confined to Mel Gibson movies. Organised crime syndicates now run entire countries—some that have nuclear, biological and chemical weapons. It's not just gangs, families or businesses anymore: it's much bigger!

Jumping now to the subject of UFOs, you may not know that hundreds of cases have been reported globally of people claiming to have been healed by aliens. I've spoken to several Australian UFO/ET experiencers who have told me of their own similar circumstances, and I was interested to read that there are many more like them. The ten cases described here have medical evidence to back them up.

The information in the Military Mind Control article goes a long way towards explaining some of the weird reports that came out of the Gulf War, especially the news footage I saw of Iraqi troops wandering around so disoriented that they were captured by a news team. They hadn't been shelled in the usual sense of the word.

So, may the season be good to you, and may this issue tide you over well for the next two months. Live long and prosper!

Duncan

WARRANTY AND INDEMNITY

Advertisers upon and by lodging material with the Publisher for publication or authorising or approving of the publication of any material INDEMNIFY the Publisher and its servants and agents against all liability claims or proceedings whatsoever arising from the publication and without limiting the generality of the foregoing to indemnify each of them in relation to defamation, slander of title, breach of copyright, infringement of trademarks or names of publication titles, unfair competition or trade practices, royalties or violation of rights or privacy AND WARRANT that the material complies with all relevant laws and regulations and that its publication will not give rise to any rights against or liabilities in the Publisher, its servants or agents and in particular that nothing therein is capable of being misleading or deceptive or otherwise in breach of the Part V of the Trade Practices Act 1974. All expressions of opinion are published on the basis that they are not to be regarded as expressing the opinion of the Publisher or its servants or agents. Editorial advice is not specific and readers are advised to seek professional help for individual problems.

© NEXUS New Times 1998

Letters to the Editor ...

UFO Secrecy in the UK

In January 1998, the [UK] Ministry of Defence (MoD) declassified into the public domain a number of previously withheld files on the UFO subject, which add greatly to our understanding of the MoD's handling of the UFO controversy in the 1960s.

Perhaps the most significant file is one which details the UFO investigative activities of a specific Defence Intelligence Staff department whose involvement in the UFO subject has long been a matter of keen debate: DI55.

In my book, *A Covert Agenda*, I revealed that DI55 was one of a number of specialist divisions which was tasked with examining UFO data; however, at the time of publication, little was known beyond that basic fact. That situation changed dramatically in January 1998.

As the file in question reveals, the public office of the MoD which was responsible for investigating UFO encounters at the time (1967) was S4 (AIR); however, the file makes it abundantly clear that S4 (AIR)'s only mandate was to make provisional enquiries with RAF Fylingdales in an attempt to determine if the reported phenomena were in any way related to the misidentification of satellites.

The file also reveals the eye-opening fact that in those instances where Fylingdales were unable to make a positive identification, S4 (AIR) were required to cease their investigations, and any further action was to be undertaken by DI55.

Most astonishing of all, the files reveal that the department within DI55 tasked with investigating UFO activity over the United Kingdom was none other than the Space Division. Moreover, the files reveal that the Space Division assumed this investigative role as far back as May 1967!

Given that the Ministry of Defence would have us believe that the focal point for UFO investigations is the Secretariat of the Air Staff, these particular files make a mockery of the MoD's assertions, particularly in light of the fact that DI55 is still heavily implicated in analysing UFO data to this day. There can now be absolutely no doubt that the Secretariat of the Air Staff is mandated to carry out only the most

basic and preliminary investigations into UFO encounters over the UK, and that the truly in-depth investigations fall (and have done for more than 30 years) into the domain of DI55.

This is a remarkable breakthrough, and one which should not come as a surprise to those of us who maintain that officialdom knows a great deal more about the UFO controversy than has previously been realised.

Nick Redfern, Pelsall, West Midlands, UK, tel 01922 691490

No Scientific Proof for HIV

At the recent 12th World AIDS Conference held in Geneva, the International Forum for Accessible Science (IFAS) hosted an official satellite meeting, "HIV testing: open questions regarding specificity".

Scientists in Perth, Western Australia, led by Eleni Eleopoulos, biophysicist, demonstrated (linked up via satellite) to a panel of international 'HIV' critics and audience that there has been no isolation of 'HIV' according to the scientifically approved standards for retroviral isolation. They concluded that the non-specific 'HIV' tests are invalid as proof for hypothetical 'HIV infection'.

Meanwhile, hunger strikers outside the Palexpo Centre demanded that Dr Bernard Hirschel, Conference Chairman, provide proof for the existence of 'HIV' (including characterisation of the putative HIV proteins and genetic material, which are essential for isolation).

At a press conference, Dr Robert Gallo was asked by Lluís Botinas (Coordinator, COBRA, Spain): "Shall you present to the hunger strikers the scientific proof of the existence of HIV, Dr Gallo?" Gallo's reply was "Shut up!". Is saying "Shut up!" a form of scientific proof?

In response to this, the hunger strikers released a press statement to the assembled world media on the fifth day of their strike: "We have come to the conclusion that 'HIV' has never been isolated. That means that nobody can confirm the existence of 'HIV'. Some direct consequences are: the 'HIV' tests are not valid and must be immediately forbidden; the fatally toxic medication (cocktails) administered as 'anti-HIV' have no

justification and must be immediately forbidden... Today our hunger strike has empowered our position. Neither President Hirschel nor the other 'AIDS specialists' has provided the scientific proof we ask for."

At the closing press conference I asked Dr Hirschel and Richard Horton, editor of the *Lancet*: "...the current indirect HIV tests and PCR are not sufficient proof that HIV has been isolated. Where is the proof that HIV exists?" None of the panel answered.

Despite 15 years of intensive AIDS research, no one can prove that 'HIV' exists.

Alex Russell, Assistant Editor, *Continuum* magazine, London, UK, tel +44 (0)171 713 7071, e-mail, continue@dircon.co.uk

Health Industry Integrity

Dear Duncan: As you are aware, we have been fighting the TGA [Therapeutic Goods Administration] since May 1997 on the basis that we believe that their draconian policies will severely restrict the sale of natural products to the public. This includes vitamins, treatments and devices.

Unfortunately, the majority of the manufacturers and importers of these products have not taken seriously what they have been told. The TGA has now been able to legislate through Parliament and bring new and serious regulations into play. The TGA's platform is basically that the public have to be protected from organisations and treatments that will give sick people false hope.

This writer believes that any therapy and any modality that helps sick people must be publicised, to give those people a choice of which path they should follow. They can't make an educated decision without the full knowledge of what is available. The danger lies in organisations promising results they can't possibly deliver, and I am a firm advocate for promoting the true benefits of one's services and products.

As someone who has worked in the field of ionisation for some thirty years, any new product that comes onto the market claiming to offer the benefits of ionisation is of great interest to me. Perhaps there is some new research that will benefit the industry and, in

turn, the general public. Unfortunately, when a product does not perform the services it guarantees, once again it is the entire industry that suffers.

Take, for example, the "Air Supply", advertised in the last [Australian] edition of NEXUS. The machine does, I'm sure, have some merit in the removal of bacteria; however, using the 134A Atmospheric Ion Analyser to measure the negative ions emitted by Air Supply, the analyser was unable to measure even one, let alone 70 trillion ions as promised. Our information indicates that the Air Supply emits only ozone, which is in fact harmful when inhaled, especially for asthmatics. (Readers can research the harmful effects of inhaling ozone by visiting the Internet website <<http://www.medscape.com>>.)

With thanks to the media, the public today are very wary of false promises, and with the TGA closely monitoring the natural health services industry, I urge my colleagues to stick to the facts about what their devices actually do.

Let's maintain the integrity of our industry and work together to provide our clients with the best possible products available for their health.

Wishing you and your readers good health,

Yours sincerely, Joshua Shaw, Managing Director, Bionic Products, PO Box 555, Robina Qld 4226, Australia, tel (07) 5593 1122, www.negativeions.com

Australian Govt Woos TNCs

Dear Duncan: I thought you'd be interested in something that could be used for your 'short snippets' at the front of the magazine.

I found a very surreptitious comment tucked away in a document produced by the Sydney City Council (*Living City*, the Council's blueprint for Sydney), which was sent to me after I responded to an advertisement in the *Sydney Daily Telegraph*, calling for residents' input into the plans for Sydney's near future. Unfortunately I can't send you my copy because it's all I have, but the book can be obtained from the Sydney City Council.

The comment on page 7, under the chapter titled "Prosperous & International", reads: "The recent moves by the federal government to provide incentives for transna-

... more Letters to the Editor

NB: Please keep letters to approx. 100-150 words in length. Ed.

tional corporations to establish regional headquarters are particularly likely to benefit this city."

Are they talking about seducing TNCs with low-tax profits, while local business foots the bill—as exposed by industry watchers such as John Cumming? And with City Council and probably local councils looking to cash in by charging rent and utilities to TNCs for premises implementation and use, is it any wonder why our financial puppets in Canberra are ever so enthusiastic about programs like the heavily flawed MAI?

Best wishes, Drew Turney, Menai, NSW, dt3@start.com.au

Alternatives to Milk and Soy?

Dear NEXUS: I and my wife have a baby girl who was born premature (29 weeks' gestation). We have had trouble with vaccinations, but the real problem now is baby formulas.

My wife is expressing breast milk at present, but will have to change to some other form soon. With "The Health Dangers of Dairy Products" (NEXUS 5/05) and "Soybean Products: A Recipe for Disaster?" (4/03), it keeps going on. Is there anyone out there who can tell us what to feed this child on, that is not going to harm it? Please hurry, as we are very concerned.

Yours, David & Sandra Cooper, Bumbaldry, NSW, Australia
[Dear David and Sandra: Breast milk is the best milk! Failing that, I would try clean, unpasteurised, goat's or sheep's milk. Ed.]

Media Misinformation

I would just like to congratulate you on the magazine. It's a very important journal and becoming more important as time goes on. I'm just an average bloke (and not some right-wing extremist) who is sick and tired of the lies and misinformation we have to put up with every day at the hands of 'mainstream' media. Thank you for being there.

Unlike the mainstream media (or the 'opinion-makers', as I like to call them), your journal gives people the opportunity to actually make up their own mind. It scares me that a lot of people don't seem to be able to do this any more. Your journal, at the very least, promotes freedom of thought.

This is what's most valuable.

Anyway, thanks again, and keep the faith. Don

CIA Posing as Mormons?

Dear Duncan & co.: I've read the interview conducted by Linda [Moulton] Howe [5/04] and wish to convey supportive experiences.

Here in Scotland, seemingly by Radio Forth only and from no other radio station, during the months after the first revelation re a supposed autopsy of an alien being, it was announced (without my hearing it) that American CIA agents were flying over to have words with British Government representatives—the news segment being partly that the CIA was very unhappy about the British Government just so easily letting this get out. The CIA was going to discuss ways of reducing public credulity of the film; and various tactics were to be discussed, especially to request derisive ridicule of the film. ...[I]t was actually mates at work who informed me of this. They said it had been broadcast twice.

So a watch was maintained of the local and national papers to get this evidentially, in print, but absolutely nothing appeared. I phoned a few papers, realising the seriousness and significance of this suppressive CIA pogrom, but they acknowledged no knowledge. So after subjecting my brain to the trouble of phoning national media radio stations and experiencing mystified or pseudo-mystified responses, there was only one thing for it: to phone my local and nearest radio station, Radio Forth and, wow, yes, they did broadcast that little piece of news! It was common knowledge as far as they were concerned—"just another piece of news, sir", "didn't see it as that big"—but yes, they did broadcast it. Some slight relief there.

Next thing, I phoned Linda Howe. (She, Michael Hesemann and I had keenly shared our annoyance at Graham Birdsall's rebuffs and jests as he, the organiser of the Leeds International UFO Conference, refused to accept the ['Roswell'] autopsy film could be sufficiently well checked out. Linda and Michael were invited speakers at this Con.) I can't remember if it was just a message left on her answerphone or whether she responded person-

ally, but I phoned her twice, with a few days between each call. The much more serious experience occurred after these calls.

Mormons came to my door the day after each call—the second time much more pushily, just about coming uninvited into the house (which I stopped them doing) as they flashed a card with my name and address on it, saying "A friend of yours said you wanted us to call"; and I was saying, "Go away! No friend of mine would ever do that!" I got them to leave with more difficulty than I had ever experienced with these sorts of people.

I was very suspicious as to their intent, intuitively linking these solicitations to my attempt to inform Linda of the CIA visits to Britain. After asking round all my friends about the Mormons having my address, none of them knew what I was talking about. All my friends are good and serious. I'm known as totally atheistic, materialistic philosophically, without the slightest interest in religion.

Philip Mantle, one of the main UFO investigators involved in releasing the autopsy film to the public, lectured about the film, ...comparing the main autopsy film to a few other mock-ups which were efforts to show how easily the whole film had been faked, and these did not look so good at all. Mantle employed them to a good opposite effect. And any film company could do exactly the same thing for television professionally. Wonder why they don't?...

David Moncoeur, Scotland, UK
[Dear David: We'll reply to your other query about videos if you could send us your address. Ed.]

Moratorium on Modified Food

Dear Duncan Roads: "Let food be your medicine and medicine your food." The Maperton Trust, which is an educational charity concerned with the holistic approach to health, has always supported the above contention and therefore has long been adamant that genetically modified ingredients of food should be treated with great reservation. The lack of supervision by statutory control increases our anxiety.

The Prince of Wales' recent statement of his belief on the situation has considerably increased

public concern about the safety of conventionally produced and processed food. Whether or not we believe in God, it is evident that there are limitations on the way humanity can improve, or distort, the wherewithal for living our lives on this planet and in this universe.

The effects of emphasising certain characteristics in bulldogs, German shepherds and other breeds of dogs and the effects of breeding for speed in racehorses are well known, but these are reversible activities and the time factor for their progression allows for assessment of the changes imposed by the breeding programme. In other activities we have not been so fortunate. The introduction of rabbits in Australia is one example of irreversible action.

The breeding of corn and grain crops to depend on applications of artificial fertiliser has increased the quantity produced, but at the expense of the health of the crops which require considerable support from agrochemicals through the growing periods, with consequent damage to the environment and the quality of food available to the bulk of the population in this country. This is reversible to some degree, although the cost of cleansing the environment is enormous. Many old varieties of crops not requiring applications of agrochemicals have been lost forever...

Because of the cross-pollination in the growing of crops, there is evidence to suggest that the genetic modifications produced recently will spread throughout the whole of the crop production within a few years. *This will be completely irreversible.* The UN, EU and our government appear not to realise this fact. They appear impotent to act in the face of commercial pressure.

We consider that genetic modification of our food poses the greatest threat to the continuance of life on this planet since the production of the atomic bomb, and we must call for an immediate and complete moratorium on the use of such modified material in the food chain for ten years to produce a breathing space to assess the threatening situation.

All good wishes, Gordon Smith, The Maperton Trust, Somerset, England, tel +44 (0)1963 32651

DIGITAL TV WATCHES YOU WATCHING TV

The launch of BSkyB digital satellite television will give Rupert Murdoch's company unprecedented power to access subscribers' televisions and record their viewing habits.

The technology is in place for Sky to find out whether vicars are watching naughty sex movies, if old ladies are obsessed by crime and violence, or whether the man next door is more interested in soap operas or gardening programs.

It is all possible because digital satellite TV will be interactive. The little black box that will be positioned on top of your television set will have a two-way communications channel. Digital television engineers say that the black box will store information on viewers' program preferences, which Sky can then upload at its convenience.

The information is commercial gold-dust. Under data protection laws, viewers would have to be told that their names were being passed on—but not necessarily that the information was being gathered in the first place.

The BSkyB set-top boxes, which the company says will be on sale from 1 October, will not include the software to monitor viewers' program choices. In



practice, though, BSkyB could at any time beam new software into set-top boxes directly from its satellite.

Viewers who fear they're being 'watched' by their television should note that there is a way of switching off Mr Murdoch. With each interactive set-top box, Sky wants to install a phone line beside the TV set. This connection allows the two-way conversation between the box and Sky's headquarters. Viewers could unplug it and still receive all of Sky's digital channels, without being interactive.

(Source: Jane Robins, *The Independent*, UK, 21 August 1998)

HUMANS AND DOLPHINS HAVE SIMILAR GENETICS

For years, marine biologists have told us that dolphins and humans share many traits including intelligence and friendliness.

"The extent of the genetic similarity came as a real surprise to us," said David Busbee of Texas A&M University, who published his results in *Cytogenetics and Cell Genetics*.

Researchers at Texas A&M University applied 'paints', or fluorescently labelled human chromosomes, to dolphin chromosomes and found that 13 of 22 dolphin chromosomes are exactly the same as human chromosomes. Of the remaining nine dolphin chromosomes, many were found to be combinations or rearrangements of their human counterparts. The researchers also identified three dolphin genes that are similar to human genes.

"Dolphins are marine mammals that swim in the ocean, and it was astonishing to learn that we have more in common with the dolphin than with land mammals," commented Horst Hameister, Professor of Medical Genetics at the University of Ulm in Germany.

(Source: Seema Kumar, *Discovery Channel Online News*, www.discovery.com)

ADVERSE DRUG REACTIONS KILL 100,000+ AMERICANS

According to a report published in a recent *Journal of the American Medical Association*, more than 100,000 Americans are killed every year by prescription and over-the-counter medicines, and a further 2.1 million are seriously injured. The report found that such reactions (which do not include prescribing errors or drug abuse) rank at least sixth among causes of death in the United States—behind heart disease, cancer, lung disease, strokes and accidents.

Researchers at the University of Toronto estimated that an average of 106,000 deaths occur annually at US hospitals due to bad reactions to drugs.

"Serious adverse drug reactions are frequent...more so than generally recognised," the researchers noted.

(Source: CNN via Internet website, http://cnn.com/HEALTH/9804/14/drug_reaction/index.html)



TELEVISION NEWS TERRIFIES AMERICAN CHILDREN

American children grow up in a culture where violence is pervasive in movies, television and even song lyrics. But researchers reported on Monday 17 August that many children trace their fears about life to one key source: TV news.

"What we call 'news' has become so sensational," said Joanne Cantor, a psychologist from the University of Wisconsin-Madison. "It's all the news that's fit to terrify."

Cantor and Barbara Wilson of the University of California, Santa Barbara, told a meeting of the American Psychological Association in San Francisco that fresh research indicated that television news, particularly local news programs, can lead to elevated fears among children.

Pointing to the explosive growth of television news outlets and a trend towards more graphic pictures of violence and mayhem, the two psychologists said television news should be closely monitored by parents and teachers for its 'fright factor' for young children.

"As children begin to understand the differences between fantasy and reality, the news becomes more frightening," Cantor noted. "These fright reactions can be intense and debilitating."

Much of the fright revolves around stories that children feel are close to their lives.

While younger children are often terrified by pictures of natural disasters, wars and famine, older children focus their fears on stories of crime and violence—particularly when they are directed at children.

"Children need to have some reasonable amount of information about the dangers that are important to them," Wilson said. "But what they are getting is exaggerated fears of things that are not necessarily the dangers they are going to encounter."

In one recent study conducted among primary school children in Santa Barbara, Wilson found that 51 per cent could describe in detail a recent television news story that had frightened them—ranging from gang violence to a natural disaster.

These fears are amplified by the fact that children, much more than adults, are likely to believe what they see on the television news.

In Wilson's study, 94 per cent of the children said they believed television news

was truthful all or most of the time.

"There is a very high perceived reality for TV news among kids," Wilson said. (Source: Andrew Quinn, Reuters, 18 August 1998)

McLIBEL CASE RETURNS TO COURT ON APPEAL

The long-running defamation case involving McDonald's and two activists who handed out pamphlets criticising the burger behemoth returned to a British court, the week of 27 July.

The "McLibel Two", Dave Morris and Helen Steel, are appealing the 1997 judge's ruling which maintained that the two had libelled McDonald's with their pamphlets. Despite the setback for the two, the judge slammed McDonald's on many counts, agreeing with Morris and Steel that the corporation does pay low wages and exploit children through its advertising, and is "culpably responsible" for animal cruelty.

Morris and Steel are maintaining in their appeal that these points from their pamphlet were so damning that they could not have harmed McDonald's reputation with other statements about the company's environmentally unsound exploitation of its Third World suppliers, its anti-union practices in Britain and the general unhealthiness of its high-fat fare.

In court on Monday, Morris and Steel, who are representing themselves as they can't afford attorneys, said they were unable to pay £20,000 (US\$33,000) to make three sets of the three-volume, 20,000-page trial transcript, one for each appellate judge. The judges decided that they would try to obtain a used copy of the transcript from

the trial judge, a spare copy from McDonald's, and then have the defendants pay a much lower sum—around £1,000 (US\$1,650)—for a third copy on computer disc.

Concerned about the tens of thousands of pages of paperwork that will fill the chambers when arguments in the longest trial in British history begin again in January 1999, the judge called for "the largest court in the building".

To learn more about the McLibel case, visit the McSpotlight website at <www.mcspotlight.org>.

(Source: Dirk Beveridge, "British 'McLibel' Case Drags On", Associated Press, 27 July 1998)

CONSPIRACY THEORY POLL

According to the results of a poll conducted by the Scripps Howard News Service and Ohio University last year: "Americans increasingly suspect the worst about their government. They think Uncle Sam may be a mass murderer, or a drug dealer, or a presidential assassin, or even a collaborator with the 'aliens'."

Results of the poll are summarised here:

- 1) Fifty-one per cent believe it is either very likely or somewhat likely that federal officials were "directly responsible" for President Kennedy's assassination.
- 2) More than one-third suspect that the US Navy, either by accident or on purpose, shot down TWA Flight 800.



3) A majority believe it is possible that the CIA "intentionally permitted Central American drug dealers to sell cocaine to inner-city black children".

4) Sixty per cent believe that the government is withholding information about Agent Orange and other military abuses in the Vietnam and Gulf wars.

5) Nearly one-half suspect that FBI agents deliberately set the fires that killed 81 Branch Davidians near Waco, Texas, in 1993.

6) After the release of the US Air Force reports stating that the "alien bodies" seen at Roswell in 1947 were actually test dummies, more people believed the government is covering up information and technology from "extraterrestrials" than before the Air Force reports.

"This is not good," commented Oklahoma Governor Frank Keating. "When we believe that our free institutions can commonly be corrupted to dark and evil purposes, it is a statement of a feeling of helplessness... We are in for some turbulent years ahead as a nation."

Curtis Gans, the Executive Director for the Washington Committee for the Study of the American Electorate, had this to say about the recent poll:

"Paranoia is killing this country. It is essentially reducing cohesion in our society and is creating fear in the minds of our citizenry."

The 'experts' agree on one thing. It would be extremely difficult, if not impos-

sible, to reverse the perception of a good portion of the public of a corrupt, secretive and conspiratorial US Government.

(Source: Website, www.sightings.com)

NEW CONTROLS ON USE OF DENTAL AMALGAM

The Swedish Government has decided to withdraw compensation for the placement of mercury amalgam fillings, effective 1 January 1999. The aim is to ban completely the use of dental amalgam within two years.

And in Australia, contrary to the claims made by the Australian Dental Association that amalgam is safe, amalgam manufacturers themselves are now acknowledging the intrinsic dangers of this material.

For example, Caulk Company, the manufacturer of Dispersalloy, published the latest Materials Safety Data Sheet (MSDS) and Directions For Use (DFU) which includes contraindications to the use of dental amalgam.

This places dentists in an interesting legal position. Dentists are obliged to be familiar with information published in MSDSs for the products they use. If a patient suffers ill-effects from the product being used in a way which is contrary to the manufacturer's directions, then the dentist may be liable for the consequences.

(Source: *Australasian Society of Oral Medicine and Toxicology*, 13 March 1998; PO Box A860, Sydney South, NSW 2000, Australia, telephone +61 (0)2 9867 1111)

GOOD-MOOD FOOD IS NO LAUGHING MATTER

Mind control drugs as medicine in food? A scheme to insert chemicals into food to make people slimmer is being funded and investigated by British Government-backed scientists. They want to change the structure of food by introducing chemicals such as tryptophan to alter people's moods, make them happier, and therefore, in theory, make them eat less.

The 'happy food' study is being funded by the Medical Research Council (which receives £300 million in state cash per year) and Unilever (producer of Wall's Ice Cream, Birds Eye and Flora products).

Critics such as Professor Tim Land, a leading authority on diet, believe the consequences could be much more sinister and far-reaching, and warn of an Orwellian nightmare. "This could be a slippery slope," said Prof. Land. "Twenty or 30 years from now, states or companies could be using this technique to exercise mass psychological control—and people will be asking why they were not told in time."

(Source: *The Mail, UK*, 10 July 1998)

MICROWAVES DISRUPT HUMAN LIGHT-EMITTING CAPACITY

Research by physicist Dr Gerard Hyland (University of Warwick, UK), into the light emitted naturally by humans, raises new concerns and possibilities as to the effect of microwave radiation—generated by mobile phones, radar or microwave ovens—on the human body.

Dr Hyland has recently presented research findings that biological systems, including the human body, generate and emit light—an extremely low intensity radiation in the form of microscopic packets of light energy, or photons.

These photon emissions are not random but display coherence similar to that of the much more intense light generated by a laser. Dr Hyland believes that the origin of this coherence is the body's own metabolism which generates its own coherent electromagnetic field. These very weak emissions of light can be viewed as an outward sign of an orderly, functioning metabolism.

This research raises serious questions about the effect of external sources of microwave radiation on living tissue and its self-generated electromagnetic patterns.

(Source: *Blazing Tattles newsletter*, vol. 7, no. 8, August 1998)



**COINCIDENCE, CONSPIRACY,
OR CARELESSNESS?**

This is a partial list of those who had (or may have had) incriminating evidence on US President Bill Clinton's alleged criminal activities, but died in suspicious circumstances. (Space constraints prevent our giving details on the mysterious deaths of Vince Foster and Ron Brown.)

Gandy Baugh—Died May 1994. Attorney for close Clinton friend Dan Lassiter, who allegedly committed suicide by jumping out of a multi-storey-building window. Lassiter was later indicted and convicted on cocaine charges, but then pardoned by Clinton.

James Bunch—Died in 1993 from a gunshot suicide. Was discovered to have a "black book" of names of influential people in Texas and Arkansas who visited certain prostitutes. A good friend of Bill Clinton.

Danny Casolaro—Died August 1991. Investigative reporter researching Mena Airport and Arkansas Development Finance Authority. His wrists were slit in an apparent suicide in the middle of his investigation. Had previously told his family his life was in danger and that he was not suicidal.

Susanne Coleman—Had an affair with Clinton when he was Arkansas Attorney General. Died of a gunshot wound to back of the head; ruled a suicide. Was pregnant at the time, allegedly to Bill Clinton.

Kathy Ferguson—Died June 1994. Ex-wife of Arkansas Trooper Danny Ferguson, found dead in her living room with a gunshot wound to the head. Death ruled a suicide, but she had several suitcases packed as if going somewhere. Danny Ferguson was a co-defendant with Bill Clinton in the Paula Jones lawsuit. Kathy Ferguson was a corroborating witness for Paula Jones.

Hershell Friday—Died 1 March 1994. Attorney; Clinton fundraiser. Died when his plane exploded; cause never determined.

Paula Grober—Died 9 December 1992. Clinton's speech interpreter for the deaf from 1978 until her death. Killed in a one-car accident; no known witnesses.

Stanley Huggins—Died from "suicide". Had been investigating Madison Guarantee, but his 300-page report was never released.

Kevin Ives and Don Henry—Died 23 August 1987. Initial report of deaths said the two teenagers had fallen asleep on rail tracks in Arkansas; local sheriff then called it a "double suicide". Later report said they had been slain before being placed on the tracks. Allegedly had stumbled upon the Mena Airport drug operation.

The following seven had information on the Ives-Henry case but died before they could give testimony:

Keith Coney—Died July 1988 when his motorcycle slammed into back of a truck.
Keith McMaskle—Died November 1988, stabbed 113 times.
Gregory Collins—Died January 1989 from a gunshot wound.
Jeff Rhodes—Died April 1989. Found shot, mutilated and burned in a trash dump.
James Milan—Died 1989, soon after Rhodes. Found decapitated. Coroner ruled death due to "natural causes".
Jordan Kettleson—Died June 1990. Shot to death in front seat of his pickup truck.
Richard Winters—Died July 1989 in a robbery setup. A suspect in the Ives-Henry deaths.

Johnny Lawhorn, Jr—Mechanic who found a check made out to Clinton in the trunk of a car left in his repair shop. Died when his car hit a utility pole.

Florence Martin—Died 1994. An accountant, subcontracting to the CIA, found in Mabell, Texas, with three gunshot wounds to the head. Martin had documents, account numbers and paperwork related to the Barry Seal Mena Airport drug-smuggling case.

James McDougal—Died 8 March 1998. Former Whitewater partner of the Clintons. Died in solitary confinement less than 24 hours before due in front of a grand jury.

Mary Mahoney—Died July 1997. A former White House intern about to go public with her story of sexual harassment in the White House. Shot five times by gunmen at the Starbucks coffee house in Georgetown.

Jerry Parks—Died 26 September 1993. Head of Clinton's gubernatorial security team in Little Rock, Arkansas, gunned down in his car at a deserted intersection outside Little Rock. Parks had been compiling a dossier on Clinton's illicit activities, which was stolen and never recovered.

C. Victor Raiser II & (son) Montgomery Raiser—Died 30 July 1992. Victor was National Finance Co-Chairman for the Clinton's election campaign. They died in a private plane crash; cause not determined.

Barry Seal—Died 1986. CIA pilot who flew drugs into Mena, Arkansas. Had compiled a "Boss Hogs" list. Machine-gunned at his home in Baton Rouge, Florida.

Bill Shelton—Died June 1994. Arkansas State Trooper and Kathy Ferguson's fiancé. Critical of the suicide ruling on her death, he was found dead at Ferguson's gravesite from a gunshot wound; also ruled a suicide.

Paul Tulley—Died 24 September 1992. Democratic National Committee Political Director, found dead in a hotel room in Little Rock, Arkansas, of unknown causes.

No autopsy allowed. Described by Clinton as a "dear friend and trusted adviser".

Jon Parnell Walker—Died 15 August 1993. Resolution Trust Corp. investigator who was looking into Whitewater/Clinton-duo ties. Mysteriously fell to his death from balcony of the Arlington, Virginia, apartment reportedly used by Vince Foster.

Paul Wilcher—Died 22 June 1993. Washington, DC, attorney investigating links between "October Surprise", the Waco massacre and drug/gun-running at Mena Airport, Arkansas. Found dead on toilet in his apartment; cause of death never determined. Delivered his 100-page report to Janet Reno a week or so before his death.

Ed Willey—Died 30 November 1993. Real-estate attorney and Clinton fundraiser, found dead in the woods of Virginia from gunshot wound to the head. Willey's death ruled a suicide, but no note or motive found. Died on the same day his wife Kathleen Willey claimed Bill Clinton groped her in the Oval Office at the White House.

John Wilson—Died 18 May 1993 from an apparent hanging suicide. A former Washington, DC, councilman, Wilson had ties to Whitewater and was preparing to start talking to the authorities about Clinton.

Barbara Wise—Died 29 November 1996. Commerce Department staffer who worked closely with Ron Brown and John Huang. Her bruised, naked body was found in her locked office at the Dept of Commerce; cause of death not announced. Curiously, Clinton made an unscheduled return to the White House from his Thanksgiving break at Camp David on the morning she died—ostensibly to retrieve a book of poetry.

This is a partial list of Bill Clinton's bodyguards who have died mysteriously:

- Major General William Robertson, Col. William Densberger, Col. Robert Kelly, Spec. Gary Rhodes—Died 23 Feb. 1993 in helicopter crash, Weisbaden, Germany.

- Major William S. Barkley, Jr, Captain Scott J. Reynolds, Sgt Brian Haney, Marine Sgt Tim Sabel—Died 19 May 1993 in helicopter crash in woods near Quantico, VA.

The above eight plus another eight bodyguards were associated with Clinton's visit to the aircraft carrier *Roosevelt* during Bosnian-Serbian peacekeeping operations.

- Steve Willis, Robert Williams, Conway LeBleu, Todd McKeegan—Died 19 April 1993 in the Waco massacre. All had similar bullet wounds to the left temple.

(Sources: Compiled from Internet websites, www.devvy.com/death_list.html and www.sightings.com)

MILITARY USE OF MIND CONTROL WEAPONS

Governments deny the existence of military devices that can alter brainwaves and emotions, and so they have no official controls over how these technologies are deployed.

by Judy Wall © 1998

First published in
RESONANCE

No. 33, April 1998

684 C. R. 535

Sumterville, FL 33585 USA

Telephone: +1 (352) 793 8748

PSY-OPS WEAPONRY USED IN THE PERSIAN GULF WAR

For years, rumours have persisted that the United States Department of Defense has been engaged in research and development of ultra-sophisticated mind-altering technology. Confirmation of this came to me recently in the form of two ITV News Bureau Ltd (London) wire service bulletins.¹

The March 23, 1991 newsbrief, "High-Tech Psychological Warfare Arrives in the Middle East", describes a US Psychological Operations (PsyOps) tactic directed against Iraqi troops in Kuwait during Operation *Desert Storm*. The manoeuvre consisted of a system in which subliminal mind-altering technology was carried on standard radio-frequency broadcasts. The March 26, 1991 newsbrief states that among the standard military planning groups in the centre of US war planning operations at Riyadh was "an unbelievable and highly classified PsyOps program utilising 'silent sound' techniques".

The opportunity to use this method occurred when Saddam Hussein's military command-and-control system was destroyed. The Iraqi troops were then forced to use commercial FM radio stations to carry encoded commands, which were broadcast on the 100 MHz frequency. The US PsyOps team set up its own portable FM transmitter, utilising the same frequency, in the deserted city of Al Khafji. This US transmitter overpowered the local Iraqi station. Along with patriotic and religious music, PsyOps transmitted "vague, confusing and contradictory military orders and information".

Subliminally, a much more powerful technology was at work: a sophisticated electronic system to 'speak' directly to the mind of the listener, to alter and entrain his brainwaves, to manipulate his brain's electroencephalographic (EEG) patterns and artificially implant negative emotional states—feelings of fear, anxiety, despair and hopelessness. This subliminal system doesn't just *tell* a person to feel an emotion, it *makes* them feel it; it implants that emotion in their minds.²

I noticed that the ITV wire service was from outside the United States. Readers of *Resonance* may recall that in the Electromagnetic Weapons Timeline in issue no. 29, reference is made to the documentary video, *Waco: The Big Lie Continues*, which contained video footage of three EM weapons. This segment of the film was from the British Broadcasting Corporation (BBC). I wondered if there was any significance to this.

At the library I pulled up back issues of my local newspaper for the same time-period of the Gulf War to see what the American wire services had said, if anything, about the use of this special PsyOps weapon. There was nothing said about it directly, but three news articles seemed related. In a news release from Associated Press during the same time-frame of the Gulf War truce, I read:

"The American pilot who shot down the second Iraqi warplane in 48 hours said Friday that continued Iraqi flights suggested that US warnings were not filtering down to Iraqi pilots... He said he hopes Saddam gets the message now. 'It's really too bad that these people have to die for their unwillingness to heed our warnings... What I really think is, they don't communicate down to the people,' he said. 'If they have a communications problem, I suggest they fix it.'"³

That may have been coincidence but two earlier news articles, dated March 1, 1991, apparently have a common origin with the ITV news bulletin. The first article⁴ tells us that approximately 100 members of the US 101st Airborne Division, fluent in Arabic, talked the enemy into surrendering. These soldiers rode in the Apache helicopter gunships that were involved in the longest helicopter-borne assault in history. They told the Iraqi troops that they would be slaughtered if they didn't give up.

"They got the point," one soldier is quoted as saying.

This all sounds very unremarkable, except when you read the editor's note: "The following dispatch was subject to US military censorship." Now why would they want to censor such a mundane tactic, except out of embarrassment that the US Army fighting forces had fallen to the level of a cheer-leading squad?...in which case they would have nixed the thing entirely.

But upon re-reading the article, we may pick out certain key phrases (emphasised in italics):

"He [the soldier interviewed] was one of dozens of Arabic speakers that played a *key role* in the allied ground attack against Iraq, and part of an attempt by the US Army to use finesse, *intelligence work* and tactics to complement brute strength."

If we fill in the missing blanks with such descriptions as "the megaphone was used to direct psychoacoustic frequencies that engaged the neural networks of the enemy's brain, causing him to think any thought and feel any emotion that the Americans chose to lay on him", then it starts to make sense. And it would no longer seem so surprising that one soldier could *talk* 450 enemy soldiers into surrendering. The possibilities are there, and, as the next article⁵ documents, that is exactly what happened. Iraqi troops gave up *en masse*.

We quote: "They were surrendering in droves, almost too fast for us to keep up with..."; "...two Iraqi majors, both brigade commanders, who gave up their entire units..."; and "...one of them gave up to an RPV [remotely piloted vehicle]. Here's this guy with his hands up, turning in a circle to give himself up to a model airplane with a camera in it."

Irrational? Not if there was also a voice being beamed into his head from that little flying toy, saying, "Give up, give up!" Otherwise, how do we account for the editor's note at the beginning of the article: "The following is based on pool dispatches that were subject to military censorship." Without that note, we could smugly think that the Iraqi soldiers were cowards or crazy, but why censor *that* idea?



MIND CONTROL WITH SILENT SOUNDS

The mind-altering mechanism is based on a subliminal carrier technology: the Silent Sound Spread Spectrum (SSSS), sometimes called "S-squad" or "Squad". It was developed by Dr Oliver Lowery of Norcross, Georgia, and is described in US Patent #5,159,703, "Silent Subliminal Presentation System", dated October 27, 1992. The abstract for the patent reads:

"A silent communications system in which nonaural carriers, in the very low or very high audio-frequency range or in the adjacent ultrasonic frequency spectrum are amplitude- or frequency-modulated with the desired intelligence and propagated acoustically or vibrationally, for inducement into the brain, typically through the use of loudspeakers, earphones, or piezoelectric transducers. The modulated carriers may be transmitted directly in real time or may be conveniently recorded and stored on mechanical, magnetic, or optical media for delayed or repeated transmission to the listener."

According to literature by Silent Sounds, Inc., it is now possible, using supercomputers, to analyse human emotional EEG patterns and replicate them, then store these "emotion signature clusters" on another computer and, at will, "silently induce and change the emotional state in a human being".

Silent Sounds, Inc. states that it is interested only in positive emotions, but the military is not so limited. That this is a US Department of Defense project is obvious.

Edward Tilton, President of Silent Sounds, Inc., says this about S-squad in a letter dated December 13, 1996:

"All schematics, however, have been classified by the US Government and we are not allowed to reveal the exact details... ..we make tapes and CDs for the German Government, even the former Soviet Union countries! All with the permission of the US State Department, of course... The system was used throughout Operation *Desert Storm* (Iraq) quite successfully."

The graphic illustration, "Induced Alpha to Theta Biofeedback Cluster Movement", which accompanies the literature, is labelled "#AB116-394-95 UNCLASSIFIED" and is an output from "the world's most versatile and most sensitive electroencephalograph (EEG) machine". It has a gain capability of 200,000, as compared to other EEG machines in use which have gain capability of approximately 50,000. It is software-driven by the "fastest of computers" using a noise-nulling technology similar to that used by nuclear submarines for detecting small objects underwater at extreme range.⁶

The purpose of all this high technology is to plot and display a moving cluster of periodic brainwave signals. The illustration shows an EEG display from a single individual, taken of left and right hemispheres simultaneously. The read-out from the two sides of the brain appear to be quite different, but in fact are the same (discounting normal left-right brain variations).

CLONING THE EMOTIONS

By using these computer-enhanced EEGs, scientists can identify and isolate the brain's low-amplitude "emotion signature clusters", synthesise them and store them on another computer. In other words, by studying the subtle characteristic brainwave patterns that occur when a subject experiences a particular emotion, scientists have been able to identify the concomitant brainwave pattern and can now duplicate it. "These clusters are then placed on the Silent Sound™ carrier frequencies and will silently trigger the occurrence of the same basic emotion in another human being!"

SYSTEM DELIVERY AND APPLICATIONS

There is a lot more involved here than a simple subliminal sound system. There are numerous patented technologies which can be piggybacked individually or collectively onto a carrier frequency to elicit all kinds of effects.

There appear to be two methods of delivery with the system. One is direct microwave induction into the brain of the subject, limited to short-range operations. The other, as described above, utilises ordinary radio and television carrier frequencies.

Far from necessarily being used as a weapon against a person, the system does have limitless positive applications. However, the fact that the sounds are subliminal makes them virtually undetectable and possibly dangerous to the general public.

In more conventional use, the Silent Sounds Subliminal System might utilise voice commands, e.g., as an adjunct to security systems. Beneath the musical broadcast that you hear in stores and shopping malls may be a hidden message which exhorts against shoplifting. And while voice commands alone are powerful, when the subliminal presentation system carries cloned emotional signatures, the result is *overwhelming*.

Free-market uses for this technology are the common self-help tapes; positive affirmation, relaxation and meditation tapes; as well as methods to increase learning capabilities.

In a medical context, these systems can be used to great advantage to treat psychiatric and psychosomatic problems. As a system for remediating the profoundly deaf, it is unequalled. (Promises, promises. This is the most common positive use touted for this technology over the past 30 years. But the deaf are still deaf, and the military now has a weapon to use on unsuspecting people with perfectly normal hearing.)

OFFICIAL DENIALS

In fact, the US Government has denied or refused to comment on mind-altering weapons for years. Only last year, *US News & World Report* ran an article titled "Wonder Weapons"—basically a review of the new so-called 'non-lethal' or 'less-than-lethal' weapons.⁷ Not one word about S-quad, although the technology had been used six years earlier!

Excerpts from the article read:

"Says Charles Bernard, a former Navy weapons-research director: 'I have yet to see one of these ray-gun things that actually works...'; and

"DARPA (Defense Advanced Research Projects Agency) has come to us every few years to see if there are ways to incapacitate the central nervous system remotely,' Dr F. Terry Hambrecht, head of the Neural Prostheses Program at NIH, told *US News*, 'but nothing has ever come of it,' he said. 'That is too science-fiction and far-fetched.'"

It may sound "science fiction and far-fetched" but it is not. However, that is just what the powers-that-be want you to believe, so as to leave them alone in their relentless pursuit of...what?

The idea behind non-lethal weapons is to incapacitate the enemy without actually killing them, or, in the case of riot control

or hostage situations, to disable the participants without permanent injury, *preferably without their knowing it*. The electromagnetic mind-altering technologies would all fall into this class of weapons, but since they are all officially non-existent, who is to decide when and where they will be used?

And why should selected companies in the entertainment industry reportedly be allowed access to this technology when the very fact of its existence is denied to the general public?

As recently as last month [February], this stonewall approach of total denial or silence on the subject still held fast, even toward committees of the US Congress!

The Joint Economics Committee, chaired by Jim Saxton (R-NJ), convened on February 25, 1998 for the "Hearing on Radio Frequency Weapons and Proliferation: Potential Impact on the Economy". Invited testimony included statements by several authorities from the military:

- Dr Alan Kehs, of the US Army Laboratories, discussed the overall RF threat.

- Mr James O'Bryon, Deputy Director of Operational Testing and Director of live fire testing for the Office of Secretary of Defense at the Pentagon, discussed the role of Live Fire Testing and how it plays a role in testing military equipment with RF weapons.

- Mr David Schriener, Principal Engineer of Directed Energy Studies with Electronic Warfare Associates and recently retired as an engineer with a naval weapons testing facility, talked about the difficulty in building an RF weapon and about the terrorist threat.

- Dr Ira Merritt, Chief of Concepts Identification and Applications Analysis Division, Advanced Technology Directorate, Missile Defense and Space Technology Center, Huntsville, Alabama, discussed the proliferation of RF weapons primarily from the former Soviet Union.

Although these statements gave information of technical interest, they are perhaps more important for the information they did *not* give: information on the existence of radio-frequency weapons that directly affect the human brain and nervous system.

KGB PSYCHOTRONICS

This technology did not spring up overnight. It has a long history of development and denials of development—by the US Government and probably half of the other governments of the world as well.

We know that the former Soviet Union was actively engaged in this type of research. In a previous article we reported that during the 1970s the Soviet KGB developed a Psychotronic Influence System (PIS) that was used to turn soldiers into programmable 'human weapons'. The system employed a combination of high-frequency radiowaves and hypnosis. The PIS project was begun in response to a similar training scheme launched in the US by President Carter, according to Yuri Malin, former security adviser to USSR President Gorbachev.⁸

In my *Electromagnetic Weapons Timeline*⁹ I covered a period of 60 years of interest and development in EM weapons—

The idea behind non-lethal weapons is to incapacitate the enemy without actually killing them, or, in the case of riot control or hostage situations, to disable the participants without permanent injury, preferably without their knowing it.

TECHNOLOGY TO BOGGLE YOUR MIND...

This is a listing of various technologies available which can be combined for use in direct or subliminal mind-control systems. Please note that these are mainly private inventions intended for positive uses, but could be applied for negative purposes as well. We have no idea what the government may have in classified research. [This listing has been considerably edited due to space considerations. Ed.]

- Silent Subliminal Presentation System, US Patent #5,159,703, Oliver Lowery, October 27, 1992. A silent communications system in which non-aural carriers in the very low or very high audio-frequency range, or in the adjacent ultrasonic frequency spectrum, are amplitude-modulated with the desired intelligence and propagated acoustically or vibrationally for inducement into the brain.
- Hearing System, US Patent #4,877,027, Wayne Brunkan, October 31, 1989. A method for directly inducing sound into the head of a person, using microwaves in the range of 100 MHz to 10,000 MHz, modulated with a waveform of frequency-modulated bursts.
- Psycho-Acoustic Projector, US Patent #3,568,347, Andrew Flanders, February 23, 1971. A system for producing aural psychological disturbances and partial deafness in the enemy during combat situations.
- Noise Generator and Transmitter, US Patent #4,034,741, Guy Adams and Jess Carden, Jr, July 12, 1977. An analgesic noise-generator.
- Method and System for Altering Consciousness, US Patent #5,123,899, James Gall, June 23, 1992. A system for altering the states of human consciousness involving the use of simultaneous application of multiple stimuli, preferably sounds, having differing frequencies.
- Subliminal Message Generator, US Patent #5,270,800, Robert Sweet, December 14, 1993. A combined subliminal and supraliminal message generator for use with a television receiver; permits complete control of subliminal messages and their presentation. Also applicable to cable television and computers.
- Superimposing Method and Apparatus Useful for Subliminal Messages, US Patent #5,134,484, Joseph Wilson, July 28, 1992.
- Method of Changing a Person's Behavior,

US Patent #4,717,343, Alan Densky, January 5, 1988. A method of conditioning a person's unconscious mind in order to effect desired change in the person's behaviour, and which does not require the services of a trained therapist.

- Auditory Subliminal Message System and Method, US Patent #4,395,600, Rene Lundy and David Tyler, July 26, 1983. An amplitude-controlled subliminal message may be mixed with background music.
- Auditory Subliminal Programming System, US Patent #4,777,529, Richard Schultz and Raymond Dolejs, October 11, 1988.
- Apparatus for Inducing Frequency Reduction in Brain Wave, US Patent #4,834,701, Kazumi Masaki, May 30, 1989.
- Ultrasonic Speech Translator and Communication System, US Patent #5,539,705, M. A. Akerman, Curtis Ayers, Howard Haynes, July 23, 1996. A wireless communication system, undetectable by radio-frequency methods, for converting audio signals, including human voice, to electronic signals in the ultrasonic frequency range, transmitting the ultrasonic signal by way of acoustic pressure waves across a carrier medium, including gases, liquids and solids, and reconvertng the ultrasonic acoustic pressure waves back to the original audio signal. This invention was made with government support under Contract DE-ACO5-84OR21400, awarded by the US Department of Energy to Martin Marietta Energy Systems, Inc.
- Non-Audible Speech Generation Method and Apparatus, US Patent #4,821,326, Norman MacLeod, April 11, 1989.
- Apparatus for Electrophysiological Stimulation, US Patent #4,227,516, Bruce Meland and Bernard Gindes, October 14, 1980.
- Method and Recording for Producing Sounds and Messages to Achieve Alpha and Theta Brainwave States and Positive Emotional States in Humans, US Patent #5,352,181, Mark Davis, October 4, 1994.
- Method and Apparatus for Translating the EEG into Music to Induce and Control Various Psychological and Physiological States and to Control a Musical Instrument, US Patent #4,883,067, Knispel et. al., November 28, 1989.
- Method of and Apparatus for Inducing Desired States of Consciousness, US Patent #5,356,368, Robert Monroe, October 18, 1994. Improved methods and apparatus for entraining human brain patterns, employing frequency-following-response (FFR) techniques and facilitating attainment of desired states of consciousness.

- Method of Inducing Mental, Emotional and Physical States of Consciousness, including Specific Mental Activity, in Human Beings, US Patent #5,213,562, Robert Monroe, May 25, 1993.
- Device for the Induction of Specific Brain Wave Patterns, US Patent #4,335,710, John Williamson, June 22, 1982. Brainwave patterns associated with relaxed and meditative states in a subject are gradually induced without deleterious chemical or neurologic side effects.
- Method and Apparatus for Repetitively Producing a Noise-like Audible Signal, US Patent #4,191,175, William Nagle, March 4, 1980.
- Apparatus for the Treatment of Neuropsychic and Somatic Diseases with Heat, Light, Sound and VHF Electromagnetic Radiation, US Patent #3,773,049, L. Y. Rabichev, V. F. Vasiliev, A. S. Putilin, T. G. Ilina, P. V. Raku and L. P. Kernitsky, November 20, 1973. Don't let the nice title fool you. This is the patent for LIDA, the infamous Soviet brainwashing machine.
- Non-Invasive Method and Apparatus for Modulating Brain Signals through an External Magnetic or Electric Field to Reduce Pain, US Patent #4,889,526, Elizabeth Rauscher and William Van Bise, December 26, 1989.
- Nervous System Excitation Device, US Patent #3,393,279, Gillis Patrick Flanagan, July 16, 1968. A method of transmitting audio information via a radiofrequency signal modulated with the audio info through electrodes placed on the subject's skin, causing the sensation of hearing the audio information in the brain.
- Method and System for Simplifying Speech Waveforms, US Patent #3,647,970, G. Patrick Flanagan, March 7, 1972. A complex speech waveform is simplified so that it can be transmitted directly through earth or water as a waveform and understood directly or after amplification.
- Means for Aiding Hearing, US Patent #2,995,633, Henry Puharich and Joseph Lawrence, August 8, 1961. Means for converting audible signals to electrical signals and conveying them to viable nerves of the facial system.
- Means for Aiding Hearing by Electrical Stimulation of the Facial Nerve System, US Patent #3,170,993, Henry Puharich, February 23, 1965.
- Hearing Device, US Patent #4,858,612, Philip Stocklin, August 22, 1989. A method and apparatus for simulation of hearing in mammals by introduction of a plurality of microwaves into the regions of the auditory cortex.

information gathered from the many articles and news clippings sent in by readers of *Resonance*. In my article on synthetic telepathy¹⁰ I traced the development of the 'voice in your head' technology dating back to 1961, all my references coming from the open scientific literature.

POWER OF THE MILITARY-INDUSTRIAL COMPLEX

Jan Wiesemann has written an apt description of the situation which now exists in the United States, about the 'forces that be' and how the situation came about:

"During the Cold War the United States not only engaged in a relatively open nuclear arms race with the Soviet Union, but also engaged in a secret race developing unconventional weapons. As the intelligence agencies (which prior to the Second World War had merely played a supporting role within the government) continued to increase their power, so did the funds spent on developing techniques designed to outsmart each other.

"And as the US intelligence community began to grow, a secret culture sprang about which enabled the intelligence players to implement the various developed techniques to cleverly circumvent the democratic processes and institutions...

"Like many other democracies, the US Government is made up of two basic parts: the elected constituency, i.e., the various governors, judges, congressmen and the President; and the unelected bureaucracies, as represented by the numerous federal agencies.

"In a well-balanced and correctly functioning democracy, the elected part of the government is in charge of its unelected bureaucratic part, giving the people a real voice in the agenda set by their government.

"While a significant part of the US Government no doubt follows this democratic principle, a considerable portion of the US Government operates in complete secrecy and follows its own unaccountable agenda which, unacknowledged, very often is quite different from the public agenda."¹¹

Jan goes on to quote one of the United States' most popular war heroes: Dwight D. Eisenhower, who served as

Supreme Commander of Allied Forces during World War II and was later elected 34th President of the United States. In his farewell address to the nation in 1961, President Eisenhower said:

"...we have been compelled to create a permanent armaments industry of vast proportions. Added to this, three and a half million men and women are directly engaged in the defence establishment. We annually spend on military security more than the net income of all United States corporations.

"This conjunction of an immense military establishment and a large arms industry is new in the American experience. The total influence—economic, political, even spiritual—is felt in every city, every state house, every office of the federal government. We recognise the imperative need for this development. Yet we must not fail to comprehend its grave implications. Our toil, resources and livelihood are all involved; so is the very structure of our society.

"In the councils of government, we must guard against the acquisition of unwarranted influence, whether sought or unsought, by the military-industrial complex. The potential for the disastrous rise of misplaced power exists and will persist. We must never let the weight of this combination endanger our liberties or our democratic processes."

INTERNATIONAL CONCERNS OVER NEW WEAPONS

The United Nations was established in 1945 with the aim of "saving succeeding generations from the scourge of war". In 1975 the General Assembly considered a draft first proposed by the Soviet Union: "Prohibition of the Development and Manufacture of New Types of Weapons of Mass Destruction and New Systems of Such Weapons".

In 1979 the Soviet Union added a list of some types of potential weapons of mass destruction:

- 1) Radiological weapons (using radioactive materials) which could produce harmful effects similar to those of a nuclear explosion;
- 2) Particle beam weapons, based on charged or neutral particles, to affect biological targets;
- 3) Infrasonic acoustic radiation weapons;
- 4) Electromagnetic weapons operating at certain radio-frequency radiations which could have injurious effects on human organs.¹²

In response, the US and other Western nations stalled. They gave a long, convoluted reason, but the result was the same.

In an article entitled "Non-Lethal Weapons May Violate Treaties",¹³ the author notes that the Certain Conventional Weapons Convention¹⁴ covers many of the non-conventional weapons—"those that utilize infrasound or electromagnetic energy (including lasers, microwave or radio-frequency radiation, or visible light pulsed at brainwave frequency) for their effects".

Harlan Girard, Managing Director of the International Committee Against Offensive Microwave Weapons, told me he believes the strategy behind the government's recent push for less-than-

lethal weapons is a subterfuge. The ones that are now getting all the publicity are put up for scrutiny to get the public's approval. The electromagnetic mind-altering technologies are not mentioned, but would be brought in later under the umbrella of less-than-lethal weapons.

These weapons were recently transferred from the Department of Defense over to the Department of Justice. Why? Because there are several international treaties that specifically limit or exclude weapons of this nature from being used in international warfare.

In other words, weapons that are barred from use against our country's worst enemies (notwithstanding the fact that the US *did* use this weapon against Iraqi troops!) can now be used against our own citizens by the local police departments against such groups as peaceful protestors of US nuclear policies.

There is evidence that the US Government has plans to extend the range of this technology to envelop all peoples, all countries.

This can be accomplished, is being accomplished, by utilising the nearly completed HAARP project for overseas areas and the GWEN network now in place in the US.

TOWARDS GLOBAL MIND CONTROL

The secrecy involved in the development of the electromagnetic mind-altering technology reflects the tremendous power that is inherent in it. To put it bluntly, whoever controls this technology can control the minds of men—all men.

There is evidence that the US Government has plans to extend the range of this technology to envelop all peoples, all countries. This can be accomplished, is being accomplished, by utilising the nearly completed HAARP project^{15,16} for overseas areas and the GWEN network now in place in the US. The US Government denies all this.

Dr Michael Persinger is a Professor of Psychology and Neuroscience at Laurentian University, Ontario, Canada. You have met him before in the pages of *Resonance* where we reported on his findings that strong electromagnetic fields can affect a person's brain.

"Temporal lobe stimulation," he said, "can evoke the feeling of a presence, disorientation, and perceptual irregularities. It can activate images stored in the subject's memory, including nightmares and monsters that are normally suppressed."¹⁷

Dr Persinger wrote an article a few years ago, titled "On the Possibility of Directly Accessing Every Human Brain by Electromagnetic Induction of Fundamental Algorithms".¹⁸ The abstract reads:

"Contemporary neuroscience suggests the existence of fundamental algorithms by which all sensory transduction is translated into an intrinsic, brain-specific code. Direct stimulation of these codes within the human temporal or limbic cortices by applied electromagnetic patterns may require energy levels which are within the range of both geomagnetic activity and contemporary communication networks. A process which is coupled to the narrow band of brain temperature could allow all

normal human brains to be affected by a subharmonic whose frequency range at about 10 Hz would only vary by 0.1 Hz."

He concludes the article with this:

"Within the last two decades a potential has emerged which was improbable, but which is now marginally feasible. This potential is the technical capability to influence directly the major portion of the approximately six billion brains of the human species, without mediation through classical sensory modalities, by generating neural information within a physical medium within which all members of the species are immersed.

"The historical emergence of such possibilities, which have ranged from gunpowder to atomic fission, have resulted in major changes in the social evolution that occurred inordinately quickly after the implementation. Reduction of the risk of the inappropriate application of these technologies requires the continued and open discussion of their realistic feasibility and implications within the scientific and public domain."

It doesn't get any plainer than that. And we do not have open discussion because the US Government has totally denied the existence of this technology.

Acknowledgements

I would like to give special thanks to: Jan Wiesemann for sending the Silent Sounds™ statement and patents which were the keystone of this article; Mike Coyle, whose computer search turned up many more related patents; Harlan Girard, who has provided numerous official government documents; and to the many who have provided newspaper clippings and articles, moral and financial support to *Resonance*, without which we'd have ceased publication long ago.

About the Author:

Judy Wall is Editor and Publisher of *Resonance*, the Newsletter of the Bioelectromagnetics Special Interest Group.

Endnotes

1. Jan Wiesemann of Germany sent me a copy of a letter from Silent Sounds, Inc., which directed the reader to their computer website. The ITV news item and EEG graph can be seen there, along with other material, if the government has not shut them down.
2. Silent Sounds, Inc. website <<http://www.mindspring.com/~silent>>.
3. Leder, Edith M., "Allies Blast 2nd Jet", Associated Press, *The Daily Commercial*, Leesburg, FL, USA, March 23, 1991.
4. Pomfret, John, "Linguists Fought Battles Using Megaphones", Associated Press, *The Daily Commercial*, March 1, 1991.
5. Crary, David, "Soldiers Recount Most Memorable Iraqi Surrenders", Associated Press, *The Daily Commercial*, March 1, 1991.
6. This sounds like the Cray supercomputer—one of which, incidentally, is located at the University of Alaska where it is used by the Department of Defense in conjunction with HAARP. Source: Begich and Manning, *Angels Don't Play This HAARP*, pp. 99-100; see endnote 15.
7. Pasternak, Douglas, "Wonder Weapons", *US News & World Report*, July 7, 1997, pp. 38-46.
8. "KGB Used PIS to Program Soldiers", *Resonance*, no. 30, March 1996, p. 29.

- Source: *Fortean Times*, no. 83, p. 13; item quoting a TV program about the Psychotropic Influence System, broadcast by ARD, Germany, May 1995.
9. Wall, Judy, "Electromagnetic Weapons", *Resonance*, no. 29, May 1995, pp. 27-33.
 10. Wall, Judy, "Synthetic Telepathy", *Resonance*, no. 29, May 1995, pp. 17-26.
 11. Wiesemann, Jan, "Unwitting Political Assassins: Clandestine Methods and Techniques applied by US Intelligence to covertly manipulate unwitting individuals to carry out or participate in political assassinations" (Masters thesis), International Relations, University of Birmingham, UK.
 12. *The United Nations and Disarmament, 1945-1985*, United Nations publication, 1985, sales no. E.8S.IX.6, pp. ix, 115. Thanks to Cheryl Welsh of Citizens Against Human Rights Abuses, for a copy this information via Harlan Girard.
 13. Rosenberg, Barbara Hatch, "Non-Lethal Weapons May Violate Treaties", *The Bulletin of the Atomic Scientists*, September-October 1994, pp. 44-45.
 14. Rosenberg gives the full name of this treaty as "Convention on Prohibition or Restriction of the Use of Certain Conventional Weapons which may be deemed to be Excessively Injurious or to have Indiscriminate Effects".
 15. Begich, Nick, PhD and Jeane Manning,

- Angels Don't Play This HAARP: Advances in Tesla Technology* (1995), Earthpulse Press, PO Box 201393, Anchorage, AK 99520, USA. See also *Resonance*, no. 30, pp. 9-22.
16. HAARP is the acronym for High-frequency Active Auroral Research Project.
 17. "Earthquakes May Affect Brain", *Resonance*, no. 29, p. 35.
 18. Persinger, M. A., "On the Possibility of Directly Accessing Every Human Brain by Electromagnetic Induction of Fundamental Algorithms", *Perceptual and Motor Skills*, June 1995, vol. 80, pp. 791-799.

Note:

This article was first published in *Resonance* (no. 33, April 1998), and has been considerably edited because of space considerations. *Resonance* is the Newsletter of the Bioelectromagnetics Special Interest Group (BEM SIG) of American Mensa Ltd. Full membership in the BEM SIG is restricted to Mensa members. Non-Mensans may be Associate members, entitled to two issues of *Resonance* and a 24-page Bibliography of BEM topics. Annual fee is USD\$10 in USA, USD\$13 in Canada and Mexico, USD\$15 elsewhere. Contact *Resonance*, 684 C.R. 535, Sumterville, FL 33585, USA, telephone +1 (352) 793 8748.

— Osteoporosis —

THE BONES OF CONTENTION

Contrary to the medical marketing hype, synthetic hormonal drugs, dairy products and most calcium supplements actually weaken the bones and have other harmful effects on health.

by Sherrill Sellman © 1998

Light Unlimited Productions
Locked Bag 8000-MDC
Kew, Victoria 3101, Australia
Telephone: +61 (0)3 9249 9591
Fax: +61(0)3 9855 9991
E-mail: golight@ozemail.com.au

A NEW DISEASE, A NEW MARKETING OPPORTUNITY

Osteoporosis is big news—and big business—these days. As a disease, it emerged out of obscurity only two decades ago to become a concern for women throughout the industrialised world. Advertising campaigns in the media and fact sheets in doctors' waiting rooms and pharmacies continually warn women of the dangers of disappearing bone mass.

The marketing hype announces that one woman in two over the age of 60 is likely to crumble from an osteoporotic fracture (yet one man in three will also get osteoporosis); that the incidence of hip fracture exceeds that of cancer of the breast, cervix and uterus combined; and that 16 per cent of patients suffering hip fractures will die within six months while 50 per cent will require long-term nursing care.¹

The statistics also say that in the United States over 20 million people have osteoporosis and approximately 1.3 million people each year will suffer a bone fracture as a result of osteoporosis. In 1993, the US incurred an estimated loss of US\$10 billion due to lost productivity and health care costs related to osteoporosis.² However, it's important to put these statistics into perspective. While it is true that death occurs in men and women who have hip fractures, these people are usually very elderly and frail. People who die from hip fractures are not only the most frail but are also ailing from other causes.

Women are constantly bombarded with the message that the war on bone loss must include calcium supplements and a daily consumption of calcium-rich foods, primarily dairy products. Doctors strongly recommend long-term use of (synthetic) oestrogen to the postmenopausal woman, and, if additional help is required, suggest the use of bone-building drugs like Fosamax. So, armed with this powerful arsenal, a woman is assured that she will walk tall and fracture-free through the latter part of her life. Unfortunately, this is far from the truth.

The most popular treatments for osteoporosis are in fact dangerous to women's health. Synthetic oestrogen is a known carcinogenic drug. Most calcium supplements are not only ineffectual in rebuilding bone, but they can actually lead to mineral deficiencies, calcification and kidney stones. And contrary to popular belief, dairy products have been proven to be a leading *cause* of bone loss.

THE OSTEOPOROSIS INDUSTRY: AN UNHOLY ALLIANCE

Osteoporosis has spawned a phenomenal growth industry. The sale of just one oestrogen drug, Premarin, grossed US\$940 million worldwide in 1996.³ The US dairy industry is thriving with its annual US\$20 billion of revenue.⁴ And sale of calcium supplements has spiralled upwards into the hundreds of millions of dollars.

The osteoporosis industry has not only created a huge market for its wares; it has also been specifically designed to target women. Obviously, the fear-mongering advertising campaign about osteoporosis as a 'silent thief', stalking women's bones, has paid off. Unfortunately, unsuspecting women are unaware they are really being stalked by an unholy alliance of the pharmaceutical companies, the medical profession and dairy industry who have orchestrated one of the most successful and well-planned marketing manoeuvres in history.

By distorting the facts, by manipulating the statistics and by withholding scientific research in the pursuit of profits, this powerful alliance has once again jeopardised lives by exposing women to an increased incidence of such illnesses as breast and ovarian cancer, strokes, liver and gall bladder disease, diabetes, heart disease, allergies, kidney stones and arthritis.

THE ROOTS OF DECEPTION

The Second World War heralded a major turning point in medicine. In the pre-war period, drug companies were mostly small businesses primarily concerned with making herbal formulas. The emergence of a more sophisticated science after the war would change the face of medicine forever.

According to Sandra Coney, author of *The Menopause Industry*: "By harnessing the power and prestige of science, medicine moved into a new 'modern' era, rendering the 'healing hands' approach obsolete. Medicine could develop a technocracy in which the experts were armed with chemistry and machinery."⁵

The development of synthetic hormones parallels the growth of the drug companies. The creation of the first synthetic oestrogen, diethylstilboestrol (better known as DES), shortly followed by the discovery of a process which synthesised steroid hormones from the urine of pregnant mares (the drug is known as Premarin), finally brought a cheap source of oestrogen onto the market.

The introduction of oral contraceptives in 1960 initiated the first widespread use of these drugs by women. A few years later, in 1966, the menopausal woman became the focus of the ever-expanding industry.

The unfortunate myth that all menopausal women would suffer total rack and ruin of their bodies and minds without supplementation of oestrogen spread like wildfire through the industrialised countries. It was a bonanza for the drug companies, as women flocked to partake of this supposed 'fountain of youth' pill.

Although warnings about oestrogen had been made sporadically for nearly 30 years, the rush for profits virtually ignored them. In particular, it was known that oestrone, the form of oestrogen in Premarin, could be associated with the development of endometrial cancer.

Sandra Coney writes: "As early as 1947, it was reported by a young researcher at Columbia University, Dr Saul Gusberg, that there was a steady stream of oestrogen users requiring diagnostic curettage for abnormal bleeding. The pathology reports from the curettes showed overstimulation of the endometrium."⁶

The bubble burst in 1975 with the publication of a major study in the prestigious *New England Journal of Medicine*, which showed that the risk of endometrial cancer increased 7.6 times in women using oestrogen. Longer-term users were at even greater risk. Women who used oestrogen for seven or more years were 14 times more likely than non-users to develop endometrial cancer.⁷

In that same month, figures from the California Cancer Registry confirmed the findings. Among white women 50 years of age or over, there had been more than an 80 per cent increase in endometrial cancer between 1969 and 1974.⁸

Evidence of oestrogen's dangers was mounting. Besides endometrial cancer, oestrogen was also linked to breast cancer, ovarian cancer, gall bladder and liver disease, and diabetes. More questions were raised about other possible side-effects.

The drug company Ayerst's rising star, Premarin, started to take a serious nosedive, and so did the company's profits. There was a dramatic fall in hormone prescriptions around the world. Oestrogen use declined by 18 per cent from 1975 to 1976 and by another 10 per cent from 1976 to 1977.⁹

THE ART OF MANIPULATING PERCEPTIONS

Something had to be done to salvage such a lucrative market. Since unopposed oestrogen was deemed as the cause of endometrial cancer, the drug companies, acknowledging their misjudgement on prescribing unopposed oestrogen to women with intact uteri, attempted to rectify their fiasco by adding a synthetic progesterone, progestin. It was argued that progestin would protect the uterus from oestrogen's proliferative effects (as is done in nature), although no long-term studies were conducted to prove the safety of combining progestin and oestrogen. Thus, hormone replacement therapy (HRT)—oestrogen therapy repackaged—made its debut.

However, women were seriously starting to question the use of synthetic hormones, so the drug companies had to find a compelling reason to lure them back on to hormones. Osteoporosis, a disease that 77 per cent of women at that time had never even heard of, was waiting in the wings. As Sandra Coney points out: "In the interests of rehabilitating HRT, women have been subjected to 'a carefully orchestrated campaign' to advocate oestrogen as a prevention for osteoporosis."¹⁰

To transform the public perception of hormones and exonerate their life-threatening effects, certain pre-conditions had to be created: the gravity of osteoporosis had to be impressed on them; women needed to understand that it was 'their' disease; menopause had to be defined as the primary cause; and women had to perceive the cancer risk as trivial when measured against the benefit.

In the medical literature, osteoporosis was originally seen as problem of bones, not women. When looking at hip fracture in terms of effect on the individual and cost to country, men have half as many fractures as women and they are more likely to die as a result of fractures than are women. Yet little is said about men and osteoporosis. The 'male factor' was intentionally played down because it didn't fit with the redefinition of the condition as a woman's disease caused by lack of

oestrogen. This strategy was necessary to promote HRT.

To accomplish this, Ayerst hired a top public relations firm to market osteoporosis. They had a big job to do. A major promotional campaign was launched, targeting women's magazines. Medical experts were marched out to preach the HRT/osteoporosis gospel on radio and TV talk shows. Health workers were enlisted to mediate the message to consumers and doctors. A disfigured old woman, bent over with 'dowager hump', was the shock-tactic symbol of the campaign and effectively struck fear into the hearts of women. Comments such as "The invalidation which can occur with osteoporosis is far more grave than the putative risk of endometrial cancer"¹¹ and "Even if you took oestrogen without progesterone, you are 15 times more likely to die from hip fracture than of endometrial cancer"¹² were used to seduce women back to hormones.

The drug company-inspired campaign to re-market oestrogen with a clean image was stunningly successful. Sandra Coney notes: "In the 1990s, the reorientation of osteoporosis as a woman's disease is complete. It is now mandatory to include osteoporosis as a major 'symptom' in any discussion of the menopause. By convincing the public and the medical profession that osteoporosis is a crippling and 'killing' disorder and oestrogen the only

"In the 1990s, the reorientation of osteoporosis as a woman's disease is complete. It is now mandatory to include osteoporosis as a major 'symptom' in any discussion of the menopause."

cure, HRT has been imbued with a kind of saintliness. HRT offers salvation where otherwise there would be none, rescuing women from an unthinkable fate as deformed old crones. In face of this, how could anyone be so ungrateful as to raise the question of risk?"¹³

Common sense was thrown out the window when it came to hormone therapy. There was no discussion of the wisdom or ethics of medicating huge numbers of asymptomatic healthy women with oestrogen drugs which are acknowledged as among the "most potent drugs in the pharmacopoeia".¹⁴ The fact that this approach has never been recommended for any other drug or for the prevention of any other condition was immaterial. The switch from HRT as a treatment to HRT as a long-term preventive therapy occurred without debate or justification.

Osteoporosis became a high-profile issue because it sells things. Besides resurrecting HRT and securing its front-line position in the treatment protocol, the dairy industry and the pharmaceutical companies that make calcium supplements hitched a ride on the osteoporosis bandwagon. Osteoporosis suited a number of vested interests. It came to the rescue of the dairy food industry at a time when sales were plummeting because of people's anxieties about eating foods containing saturated fats. Calcium was added to skim milk, thus transforming milk into a product that could be marketed as healthy—a prevention against osteoporosis. Women were warned that their bones would become brittle if they didn't take extra calcium by way of the new calcium-fortified dairy products.¹⁵

The makers of calcium supplements also claimed that their products could prevent bone loss, despite the fact that there is no absolute evidence that this is true. By 1986 American consumers were spending US\$166 million on calcium supplements. Prior to the calcium craze, and contributing to it, the US National Institutes of Health (NIH) had recommended in 1985 that women should increase their daily calcium allowance. By 1989 the NIH was warning that the promoters of calcium "promise more than calcium is going to deliver".¹⁶

THE BARE BONES ABOUT BONES

To understand the many myths about osteoporosis and its prescribed treatments, it is vital to understand the nature of bones. Bone is living tissue which undergoes constant transformation. Bone might appear to be static, but its basic components are continually renewed. At any given moment in each of us, there are from 1 to 10 million sites where small segments of old bone are being dissolved and new bone is being laid down to replace it. Bone tissue is nourished and detoxified by blood vessels in constant exchange with the whole body.¹⁷ A healthy body will ensure healthy bones.

Bone-forming cells are of two different kinds: osteoclasts and osteoblasts. The job of osteoclasts is to travel through the bone in search of old bone that is in need of renewal. Osteoclasts dissolve bone and leave behind tiny unfilled spaces. Osteoblast cells then move into these spaces in order to build new bone. In this way, bone heals and renews itself in a process called "remodelling". This self-repair capability is extremely important. Imbalances in bone-remodelling contribute to osteoporosis. When more old

bone is eaten up than new bone is laid down, bone loss occurs.

Bone turnover never stops completely. In fact, after about the age of 50 the rate increases, though it's not quite co-ordinated. The bone-building cells, the osteoblasts, become less and less capable of completely refilling the spaces made by the osteoclasts.¹⁸ The peak amount of bone you started with and the rate of this loss determines the density of your bones. Density varies greatly in different individuals, cultures, races and sexes.

As Dr Susan Love, author of *Dr Susan Love's Hormone Book*, explains: "...the correct term for low bone density is 'osteopenia'. It is only one factor in osteoporosis and the fractures that result from it. Another factor is the micro-architecture of the bone. As osteoclasts absorb more bone than is rebuilt, the micro-architecture becomes fragile. As it weakens, the wrist and hip become more vulnerable to fracture. Your vertebra doesn't really fracture or crack but collapses on itself, causing loss of height, and if enough vertebra are crushed, a dowager hump is created."¹⁹

How real is this "dowager hump" syndrome? According to Dr Bruce Ettinger, Associate Clinical Professor of Medicine at the University of California and an endocrinologist: "...women shouldn't worry about osteoporosis. The osteoporosis that causes

Osteoporosis suited a number of vested interests. It came to the rescue of the dairy food industry at a time when sales were plummeting because of people's anxieties about eating foods containing saturated fats.

pain and disability is a very rare disease. Only 5% to 7% of 70-year-olds will show vertebral collapse; only half of these will have two involved vertebrae; and perhaps one-fifth or one-sixth will have symptoms. I have a very big referral practice and I have very few bent-over patients. There's been a tremendous hullabaloo lately, and there are a lot of worried women—and excessive testing and administration of medications."²⁰

The medical definition of osteoporosis used to be "fractures caused by thin bones". It has since been redefined to "a disease characterised

by low bone mass and micro-architectural deterioration of bone tissue which lead to increased bone fragility and a consequent increase in fracture risk".²¹ However, there is a problem with defining osteoporosis as a disease, not a fracture. Low bone mass is only one risk-factor for osteoporosis, not osteoporosis itself. It's a warning sign that might be useful, so you can begin to consider ways to keep the disease itself from occurring. Dr Love offers a striking analogy: "This is like defining heart disease as having high cholesterol rather than having a heart attack. Needless to say, this new definition has increased the number of women and men who have osteoporosis."²²

Although this new disease has two components—bone mass and micro-architecture—micro-architecture is virtually ignored. The problem is that, presently, only bone density can be measured. Also, not everyone with low bone density will get fractures. For instance, Asian women have low bone density yet have very low rates of bone fractures.

The general assumption has been that once bone reaches a certain level of thinness, it becomes subject to fractures more easily. Now that more is known about bone physiology, it is clear that this is not the full story. Bone does not fracture due to thinness alone. Leading bone expert, and author of *Better Bones, Better Body*, Susan E. Brown, PhD, states: "Osteoporosis by itself does not cause bone fractures. This is documented simply by the fact that half of the population with thin osteoporotic bones in fact never fracture."²³

Lawrence Melton of the Mayo Clinic noted as early as 1988: "Osteoporosis alone may not be sufficient to produce such osteoporotic fracture, since many individuals remain fracture-free even within the sub-groups of lowest bone density. Most women aged 65 and over and men 75 and over have lost enough bone to place them at significant risk of osteoporosis, yet many never fracture any bones at all. By age 80, virtually all women in the United States are osteoporotic with regard to their hip bone density, yet only a small percentage of them suffer hip fractures each year."²⁴

Why does there seem to be many more women now with osteoporosis than in the past? As Dr Love explains: "...part of that increase is nothing but a change in definition... Needless to say, the broader the criteria used to define osteoporosis, the more women will fall into that category. The level of bone density that defines osteoporosis has been set rather high, with the result that most older women will fall into the 'disease' category—which is very nice for the people in the business of treating disease."²⁵

THE MYTHICAL CAUSES OF OSTEOPOROSIS

There are many cultures in the world where the postmenopausal woman is fit, active and healthy until the end of her life. It is equally true that the women in these cultures do not suffer from osteoporosis. If menopause itself were indeed one of the causes of osteoporosis, all women throughout the world would be handicapped with fractures. This is clearly not the case.

The Maya women live for 30 years after menopause but they don't get osteoporosis, they don't lose height, they don't develop dowager hump and they don't get fractures. A research team analysed their hormone levels and bone density and found that their oestrogen levels were no higher than those of white American women—in some cases they were even lower. Bone density tests showed that bone loss occurred in these women at the same rate as their US counterparts.²⁶

It used to be thought that all women have a considerable decrease in bone from lower oestrogen levels at menopause, thus oestrogen deficiency was said to be the cause of osteoporosis. Continuing research has disproved this idea. Studies following individual women's bone density over time have shown that although some women lose a lot of bone with menopause, others lose comparatively little; also, that some loss starts earlier.²⁷ One study using urine tests to measure calcium loss found that some women are 'fast losers' and others are naturally 'normal losers'.

If osteoporosis is due to oestrogen deficiency, we would expect to find lower oestrogen levels in women with osteoporosis than in women without the disorder. However, studies have shown that sex hormone levels were found to be similar in postmenopausal women both with and without osteoporosis.²⁸

Dr Susan Brown comments: "Even in the United States, where osteoporosis is common, many older women remain free from the disorder. In addition, the higher male and lower female osteoporosis rates found in some cultures do not support the notion that excessive bone loss is due to declining ovarian oestrogen produc-

tion. Adding another dimension, we find that vegetarian women have lower oestrogen serum levels yet higher bone density than their meat-eating peers."²⁹

Obviously it is a gross oversimplification to say that osteoporosis is a single, inevitable disease which occurs in all women at menopause. A woman who has her ovaries surgically removed has double the loss of bone compared to a woman going through a natural menopause. Since the ovaries continue to produce hormones in addition to oestrogen after menopause, it is obvious that oestrogen is only one factor connected to bone loss.

Dr Jerilynn Prior, Professor of Endocrinology at the University of British Columbia, has conducted research that seriously challenges oestrogen's key role in preventing bone loss. Her research confirms that oestrogen's role in combating osteoporosis is only a minor one. In her study of female athletes she found that osteoporosis occurred to the degree that the athletes became progesterone-deficient, even though their oestrogen levels remained normal.

Dr Prior continued her research with non-athletic women, and they showed the same results. While both these groups of women were menstruating they had anovulatory (not ovulating) cycles and were thus deficient in progesterone. As a result of her extensive research, she confirmed that it is not oestrogen but *progesterone* which is the key bone-building hormone. Such studies seriously challenge the oestrogen deficiency—osteoporosis link.³⁰

Dr John Lee—doctor, researcher and a leading authority on natural hormone treatments—conducted a three-year study treating 63 postmenopausal women with natural progesterone. The women showed a 7 to 8 per cent increase in bone density in the first year; a 4 to 5 per cent increase in the second year; and a 3

to 4 per cent increase in the third year. This finding has been reinforced by Dr William Regelson, another expert on hormones: "Given the fact that 25 per cent of all women are at risk of developing osteoporosis, I think it is unconscionable that progesterone's role in this disease has been neglected."³¹

While oestrogen plays an important and complex role in bone health maintenance, osteoporosis cannot simply be attributed to lower oestrogen levels occurring at menopause. Numerous dietary, lifestyle and endocrine factors contribute to the development of excessive bone loss. Osteoporosis is not simply produced by the lack of one single hormone.

The intention to make menopause and oestrogen deficiency the major causes of osteoporosis gave HRT new legitimacy as a long-term preventive treatment for osteoporosis. Even though oestrogen has been shown to have some effectiveness in slowing down the rate of bone loss because it slows the rate at which bone cells are resorbed, it cannot rebuild bone. Unfortunately, this benefit is not experienced by all women. To have any effectiveness for the postmenopausal women most at risk—those 70 years of age or older—women must stay on oestrogen continuously for decades.

This, then, becomes quite a serious dilemma for women. It is now known that HRT increases the incidence of breast cancer by 10 per cent a year for each year of use. Ten years of taking HRT

THE REAL BONE CALCIUM THIEVES

- Acid/alkali imbalance • Alcohol • Antacids containing aluminium • Anorexia
- Antibiotics • Caffeine • Diuretics
- Endocrine imbalance of parathyroid, thyroid, adrenal, ovaries, kidneys • Excessive animal protein and dairy products • High saturated-fat consumption • High salt intake
- History of dieting • Hysterectomy; removal of ovaries • Indoor existence; lack of vitamin D
- Oral contraceptive pill and Depo-Provera
- Pharmaceutical drugs and treatments, i.e., anti-convulsants, chemotherapy, radiation, psychotropic drugs, e.g., Valium and Librium
- Poor digestion • Sedentary lifestyle • Stress/adrenal exhaustion • Sugar consumption
- Tobacco • Toxic metals, e.g., lead, mercury, cadmium, aluminium, tin

increases the risk to 100 per cent.³² It is obvious that the many risks of HRT far outweigh the rather limited beneficial effects on bone, especially when there are many other safe and effective alternatives. Is the increased risk of a life-threatening disease really worth it?

THE CALCIUM DEFICIENCY MYTH

When asked about the causes of osteoporosis, most people will chime in with "Lack of calcium". This idea is reinforced on a daily basis as women are reminded to drink their three glasses of milk a day and take their calcium supplements. Even young, healthy, non-osteoporotic women are paranoid about potential bone loss and take measures to shore up their bone strength with plenty of calcium. Fear of insufficient calcium has become a national obsession. Is there really a national calcium deficit?

Since bone is largely composed of calcium, it might appear logical to link calcium intake with bone health. Western women are now encouraged to consume at least 1,000 to 1,500 mg of calcium daily. It is curious, however, when cross-cultural data clearly shows that in less-developed countries—where people consume little or no dairy products and ingest less total calcium—there are much lower rates of osteoporosis.³³

The Bantu of Africa have the lowest rates of osteoporosis of any culture, yet they consume from 175 to 476 mg of calcium daily. The Japanese average about 540 mg daily, but the early postmenopausal spinal fractures so common in the West are almost unheard of in Japan. Overall, their spinal fracture rate is one-half that of the US. All this is true, even though the Japanese have one of the longest life spans of any population. Studies of populations in China, Gambia, Ceylon, Surinam, Peru and other cultures all report similar findings of low calcium intake and low osteoporosis rates.³⁴ Anthropologist Stanley Garn, who studied bone loss over a 50-year period in people in North and Central America, failed to find a link between calcium intake and bone loss.³⁵

While it is agreed upon that adequate calcium is absolutely necessary for development and maintenance of healthy bones, there is no one standard ideal calcium intake. It is also obvious from these studies that high calcium intake is not necessary for healthy bones.

There is certainly a problem with bone health in Western cultures. However, other vital factors that determine the complex process of healthy bones must be understood. Bones are affected by: the intake of other bone-building nutrients; consumption of potentially bone-damaging substances like excess protein, salt, saturated fat and sugar; the use of some drugs, alcohol, caffeine and tobacco; the level of physical exercise; exposure to sunlight and environmental toxins; the impact of stress; the removal of the ovaries and uterus; and many factors that limit endocrine gland functioning.

There are at least 18 key bone-building nutrients essential for optimum bone health. If one's diet is low in any of these nutrients, the bones will suffer. They include phosphorus, magnesium, manganese, zinc, copper, boron, silica, fluorine, vitamins A, C, D, B6, B12, K, folic acid, essential fatty acids and protein.

The body uses minerals only when they are in proper balance. For example, girls who consume diets high in meat, soft drinks

and processed foods which have high levels of phosphorus have been found to have an alarming loss of bone mass.³⁶ Too high a ratio of phosphorus in relationship to calcium will cause calcium to be pulled out of the bones in an attempt to compensate.

Scientific evidence shows unequivocally that, by themselves, calcium supplements just don't work.³⁷ And contrary to popular thought, calcium supplementation does not reduce the risk of fracture. There is now evidence that a high calcium supplement level is actually associated with a 50 per cent increase in the risk of fracture.³⁸ However, as yet, there remains no proof that increasing the calcium intake with supplements or diet after menopause prevents fractures. In fact, several studies indicate that it doesn't really appear to lower the incidence of fractures at all. In *Science* (August 1978) it was stated the "link between calcium and osteoporosis was made on insufficient grounds" and that the advertisers were way out ahead of the scientific evidence. But a diet rich in

calcium in early childhood and premenopausal years does build stronger bones, reducing risk of thin bones after menopause.

The worst calcium supplements are bone meal, oyster shell and dolomite because they cannot be efficiently absorbed and may contain lead. Excessive calcium intake also leads to constipation and, more worrisome, kidney stones and calcification of the joints. The most effective form of supplementation is hydroxyapatite (especially if it is formulated with boron). This is the most natural of all calcium supplements and a

complete bone food.³⁹

And what about dairy foods for bones? Dr Michael Colgan, a well-known researcher in nutrition, an author and the founder of the Colgan Institute in the US, has said: "The medical advice to drink milk to prevent osteoporosis is self-serving poppycock." After all we've been indoctrinated with, it's a shocking revelation to discover that dairy products contribute to bone loss. The countries that consume the highest amounts of dairy products also have the highest rates of osteoporosis; the non-dairy-consuming countries have the lowest osteoporosis rates.

In the body's wisdom, the highest priority is to maintain the proper acid/alkali balance in the blood. A high protein diet of meat and dairy products poses a great osteoporosis risk because it makes the blood highly acidic. Calcium must then be extracted from the bones in order to restore proper balance. Since calcium in the blood is used by every cell in the body to maintain its integrity, the body will sacrifice calcium in the bone to maintain homeostasis in the blood.

In a year-long study of 22 postmenopausal women, there was no significant improvement in calcium levels when their diets were supplemented daily with three 300 mL glasses of skim milk (equivalent to 1,500 mg of calcium). The authors stated this outcome was due to "the average 30% increase in protein intake during milk supplementation". Since skim milk contains almost double the protein of whole milk, it promotes an even greater rate of calcium excretion.⁴⁰

In a recently published 12-year study of nearly 78,000 women it was concluded that milk consumption does not protect against hip or forearm fracture. Female milk-drinkers actually had a significantly increased risk of fracture, and teenage milk-drinking was not protective against osteoporosis.⁴¹

In a year-long study of 22 postmenopausal women, there was no significant improvement in calcium levels when their diets were supplemented daily with three 300 mL glasses of skim milk (equivalent to 1,500 mg of calcium).

There are still other problems with dairy products. They contain antibiotics, oestrogen hormones, pesticides and an enzyme that is a known factor in breast cancer. In addition, another recent study revealed that lactose-intolerant women who drank milk were at greater risk of ovarian cancer and infertility.⁴²

THE BONE-BUILDING DRUGS SCAM

The drug companies boast one other weapon in their anti-osteoporosis arsenal: medication that promises to halt bone loss. One of the drugs in favour is Fosamax, the only non-hormonal drug approved by the US FDA to treat osteoporosis. Studies of this drug were cleverly stopped after four to six years. This is just the point at which the fracture rate for women taking similar drugs began to rise. So, although Fosamax will superficially appear to increase bone density, in reality it decreases bone strength. Fosamax is a metabolic poison and will actually kill osteoclast cells which are required to maintain dynamic bone equilibrium.⁴³ In addition, Fosamax can cause severe and permanent damage to the oesophagus and stomach. It is also hard on the kidneys and can cause diarrhoea, flatulence, rashes, headaches and muscular pain. Rats given high doses developed thyroid and adrenal tumours. Fosamax also causes deficiencies of calcium, magnesium and vitamin D, all essential for the bone-building process.⁴⁴

BUILDING HEALTHY BONES

It is clear that the osteoporosis treatments doctors most often recommend to women—HRT, calcium supplements, dairy products and drugs—have certainly benefited the medical establishment and drug companies most of all. The real long-term benefit to women is minimal at best, and life-threatening at worst.

Fortunately there are other options that not only can prevent further deterioration of bone density and poor bone repair but can actually increase bone mass in women of all ages. According to Dr Susan Brown, the six intervention areas that form the strongest, surest program for building and repairing bone include: maximising nutrient intake, building digestive strength, minimising anti-nutritive intake, exercising (especially with weights), developing an alkaline diet and promoting endocrine vitality. She

believes that "no matter where you are on the bone health continuum, no matter what your lifestyle has been, it is never too late to begin rebuilding healthy bones".⁴⁵

Some of the leading lights in safely preventing, halting and restoring bone mass include supplementation with natural progesterone, hydroxyapatite, calcium citrate, or Chinese herbal formulas. When it comes to ensuring healthy bones, it's important to remember it's not only about what one puts in the body but also what one doesn't. (See box, *The Real Bone Calcium Thieves*.)

More and more studies are validating the extremely beneficial effects of a regular weight-bearing exercise program in increasing bone density in postmenopausal women. A woman's lifelong tendency to diet has been an unrecognised cause of bone loss. At least seven well-controlled studies have shown that when a woman diets and loses weight, she also loses bone. A recent study found that in less than 22 months, women who exercised three times a week increased their bone density by 5.2 per cent, while sedentary women actually lost 1.2 per cent.⁴⁶ Effective strength-training includes such exercise as walking uphill, bicycling in low gear, climbing steps and training with weights.

Osteoporosis is not an ageing disease or an oestrogen or calcium deficiency but a degenerative disease of Western culture. We have brought it upon ourselves through poor dietary habits and lifestyle factors, and exposure to pharmaceutical drugs. It is our ignorance that has made us vulnerable to the vested interests that have intentionally distorted the facts and willingly sacrificed the health of millions of women at the altar of profit and greed. It is only by our willingness to take responsibility for our bodies and make the commitment to return to a healthy, balanced way of life that we'll be able to walk tall and strong for the rest of our lives.

About the Author:

Sherrill Sellman is the author of *Hormone Heresy: What Women MUST Know About Their Hormones*. Due to the great demand from women around Australia for counselling on hormone health and natural hormone alternatives, and for referrals to sympathetic health practitioners, Sherrill has started the Natural Hormone Health Practising and Referral Service. It will be available from 16 November 1998 by calling 1902 211 191 (in Australia).

Endnotes

- Royal Australasian College of Physicians, Working Party on Osteoporosis, report, 1991.
- USA Health Facts, www.MedicineNet.com, p. 1.
- Reuters news release, 5 November 1996.
- Transcript of press conference interview with Robert Cohen, 10 June 1998, website <www.notmilk.com>.
- Coney, Sandra, *The Menopause Industry*, Spinifex, Victoria, Australia, 1993, p. 163.
- op. cit., p. 164.
- Ziel, H. and W. Finkle (1975), "Increased risk of endometrial carcinoma among users of conjugated estrogen", *New England Journal of Medicine* 293:1167-70.
- Coney, op. cit., p. 165.
- Donaldson, Angela, "Oestrogen: the menopause miracle", *Woman's Day*, New Zealand, 10 February 1991, pp. 28-29.
- Coney, op. cit., p. 169.
- Resnick, N. and S. Greenspan (1989), "Senile osteoporosis reconsidered", *JAMA* 261(7):1025-29.
- Hutchinson, T., S. Polansky and A. Feinstein (1979), "Post-menopausal estrogens protect against fractures of hip and distal radius: a case control study", *Lancet* 2:705-9.
- Coney, op. cit., p. 171.
- Salhanic, H. A. (1974), "Pros and cons of estrogen therapy for gynecologic conditions", in *Controversy in Obstetrics and Gynecology* (D. Reid and C. D. Christian, eds.), Saunders, Philadelphia, pp. 801-08.
- Bonn D., "HRT and the Media", paper given at Women's Health Concern Conference, Cardiff, 31 May 1989.
- Stevenson, J., "Osteoporosis: the silent epidemic", *Update*, 1 August 1986, pp. 211-16.
- Frost, H. (1985), "The pathomechanics of osteoporosis", *Clin. Orthop.* 200:198-225.
- Love, Susan, MD, *Dr Susan Love's Hormone Book*, Random House, New York, 1997, p. 77.
- ibid.
- Coney, op. cit., p. 107.
- Consensus Development Conference, "Prophylaxis and treatment of osteoporosis", Conference Report, *Am. J. Med.* 1991:107-110.
- Love, op. cit., p. 79.
- Brown, Susan, PhD, *Better Bones, Better Body*, Keats Publishing, Connecticut, USA, 1996, p.38.
- ibid.
- Love, op. cit., p. 83.
- op. cit., p. 85.
- ibid.
- Riggs, B. and L. Melton, "Involutional Osteoporosis" (1986), *New England Journal of Medicine* 26:1676-86.
- Brown, op. cit., p. 66.
- Sellman, Sherrill, *Hormone Heresy: What Women MUST Know About Their Hormones*, GetWell International, Hawaii, 1998 (US ed.), p. 125.
- ibid.
- Colditz, G. A. (1998), "Relationships between estrogen levels, use of hormone replacement therapy and breast cancer", *J. NCI* 90(11):814-823.
- Melton, L. and B. Riggs, "Epidemiology of Age-related Fractures", in *The Osteoporotic Syndrome: Detection, Prevention and Treatment* (L. Avioli, ed.), Grune & Stratton, New York, 1983, pp. 43-72.
- Brown, op. cit., pp. 62-63.
- Garn, S., "Nutrition and bone loss: introductory remarks", *Fed. Proc.*, Nov-Dec 1976, p. 1716.
- Brown, op. cit., p. 126.
- Colgan, M., Dr, *The New Nutrition*, Apple Publishing, Canada, 1995, p. 62.
- Robert Cohen's website, <www.notmilk.com>.
- Beckham, Nancy, *Natural Therapies for Menopause and Osteoporosis*, published by Nancy Beckham, NSW, Australia, 1997, p. 56.
- Cottrell, M. and N. Mead, "Osteoporosis and the Calcium Craze", *Australian Wellbeing*, no. 57, 1994, pp. 70-75.
- Fesknanich, D., W. C. Willet, M. Stamfer and G. A. Colditz (1997), "Milk, dietary calcium and bone fractures in women: a 12-year prospective study", *Am. J. Public Health* 87:992-997.
- Colgan, op. cit., p. 60.
- Health News You Can Use*, newsletter, no. 60, 2 August 1998; website <www.mercola.com>.
- The John R. Lee, MD, Medical Letter*, July 1998.
- Brown, op. cit., p. 219.
- Nelson, M., PhD, *Strong Women Stay Slim*, Lothian, Melbourne, Australia, 1998, p. 10.

SPOOKS, WHISTLEBLOWERS AND FALL GUYS

**Whistleblower
Rodney Stich
exposes more crime
and corruption
perpetrated by US
Government
representatives in
collusion with
shady military/
intelligence
operatives and
Mafia figures.**

Part 2 of 2

by Uri Dowbenko © 1998

alt.media
PO Box 43
Pray, Montana 59065, USA
Email: u.dowbenko@mailcity.com

Former US Federal Aviation Administration (FAA) investigator Rodney Stich is the author of several exposés: *Defrauding America*, *Unfriendly Skies* and *Disavow*. By virtue of his life work, he has become a one-man whistleblowers' clearinghouse.

"You could put it that way. I've been saying that I've become a focal point for whistleblowers," said Stich in a recent interview. "One of them was an FBI agent for 10 years—Richard Taus. He worked with Louis Freeh, the FBI director, on the Pizza Connection drug cases, and during this investigation he found evidence of CIA involvement with organised crime in the New York City area. Another is Jimmy Rothstein who was on the New York Police Department Vice Squad and discovered the same thing: CIA drug trafficking with organised crime. Both of those people suffered retaliation."

FBI WHISTLEBLOWER RICHARD M. TAUS

"They either had adverse job performance reports or had false charges filed against them, as in Richard Taus's case," said Stich. "He's in prison now, and he'll be there for the next 80 years if we don't do something about it."

"Richard Taus was a highly decorated Vietnam helicopter pilot," continued Stich. "He's had many high commendations. He was a Lieutenant Colonel in the National Guard in the New York City area as a helicopter pilot. He was also an FBI agent."

"Incidentally, while he was in Vietnam, he reported drug trafficking by the CIA in Air America. Somehow Congress heard about it, and a congressman came over there. He discovered about 2,000 pounds of drugs in an Air America plane that was forced down. Taus was in a helicopter so he quickly went there to help the crew, and while he's there his crew chief sees all of the drugs on board the plane. So Taus reports it when he gets back to his base. The congressman came over and he was told that this was for the crew's own use, that it was not for distribution."

"But 2,000 pounds?" Stich asks. "They're still probably using it."

And how did Taus become a CIA fall guy?

"They set him up the same way they set up two other sources I have: Jimmy Rothstein, and someone who was a member of the Mafia in New York who was also a CIA paymaster working with both the Mafia and the CIA. I've talked to his daughter about it."

Stich was referring to Dee Ferdinand, daughter of Mafia figure Albert Carone.

"Having grown up in a Mafia family and been friends with top Mafia bosses, Dee was very helpful in explaining the complex relationship between the Mafia and the CIA. She explained details of her father's activities as a CIA paymaster, moving money to and from the Mafia families in New York, New Jersey and Pennsylvania, the CIA and the Mossad, and payoffs to the New York City Police Department."

Not to forget, Mob boss Sam "Momo" Giancana used to say: "The Outfit and the Agency—it's like two sides of the same coin."

"The Outfit" is of course the Mob, or Mafia, and "the Agency" is the CIA.

Regarding the set-up, Stich added: "They suddenly charged Taus with 'playing with little boys'. It doesn't seem to be too hard to get little boys to testify against him—especially if their families are under threat of prosecution."

So now Taus is in prison on phoney paedophilia or child molestation charges?

"Yes," said Stich. "First the feds filed charges against him, and—as Ted Gunderson, former Chief Special FBI Agent in the Los Angeles area, has said—there's no federal offence for that. The feds filed it just long enough to get Taus out of circulation because Bush was coming up for re-election and some of the corruption had to do with Bush."

"Then, after Taus was removed from active duty with the FBI, the state of New York took over. With Taus, it will be more difficult because it's a state offence. If it was federal, it's easier to show retaliation. When you have to go to the state level, it's more difficult to show that it's retaliation for reporting corruption by high-level federal officials."

LAPD WHISTLEBLOWER CONFIRMS CIA/MAFIA DRUG TRAFFICKING

In his testimony before the Senate Select Committee of Intelligence, former Los Angeles Police Department officer Michael C. Ruppert said: "The 'Amadeus' missions are the single most important piece of investigative work, other than my own experience, which I have to add to this investigation. My investigations into 'Amadeus' have detailed the life of Albert V. Carone, a retired New York Police detective who, at his death from 'chemical toxicity of unknown etiology' [CIA cancer?], held the rank of full Colonel in the US Army Reserves."

Ruppert continued: "I have held this man's personal phone book in my hands. In it I found home addresses and phone numbers of DCI [Director, Central Intelligence] William Casey, Paul Helliwell, a long-established CIA covert operative connected to drugs, General Richard Stillwell and many other CIA figures. I also found the home addresses and phone numbers of Mafia figures including Pauly Castellano, head of the Gambino crime family, and many other known Mafia figures..."

"In the years before his death, Carone made open statements to family members not only about the hands-on drug-dealing roles of such figures as Oliver North, Richard Secord, Elliot Abrams, George Bush, John Poindexter, Felix Rodriguez and Chi Chi Quintero, but about murder and torture.

"Carone frequently referred to 'Amadeus' as the CIA's umbrella governing his laundering of drug money through a host of banks worldwide. Some bank records and account numbers connected to the Bahamas and the Jersey Islands still remain. He also described the operations of such Iran-Contra era drug-kingpins Rafael Caro Quintero and Miguel Angel Felix Gallardo. When he died in 1990, he left behind records, a passport and a great many leads which totally substantiate these allegations..."

"We have since obtained tape-recorded statements from James Robert Strauss [a Carone associate] that 'Amadeus' was none other than George Herbert Walker Bush. The tape is safely stored, awaiting an opportunity to be presented to the American people..." (For details about Ruppert's newsletter, *From the Wilderness*, see bibliography at end of this article.)

CIA WHISTLEBLOWER STEPHEN CRITTENDEN

To his credit, Rodney Stich's publication of *Defrauding America* has helped release former federal-agent whistleblowers from prison, especially Stephen Crittenden, head of Crittenden Air Transport, a highly secret CIA front corporation.

"Crittenden was the fellow who was head of a CIA airline for 16 years," said Stich. "He was hauling drugs for the CIA and he's given me detailed affidavits about it. He got tired of it after a while and shut down the airline. He had C-130s all over the world and especially in the Far East.

"So naturally the CIA wasn't happy with him. Eventually they filed false charges against him," Stich continued. "He went to prison. He was complaining to his CIA handler and the handler said: 'Just keep quiet and we'll get you out before long.' Well, they didn't get him out. About the time he was to be released five years later, they filed new charges against him that would get him 20 years. And that's what the Justice Department was requesting. About this time he contacts me. What I did was file a 'friend of the court' brief in the US District Court in Phoenix, Arizona, and attach to it an affidavit that Crittenden gave me describing in detail the drug trafficking he was doing, and also a draft of the chapter on Crittenden that would be in the next book [the next edition of *Defrauding America*].

"At the hearing, the judge cleared out the courtroom and gave Crittenden a choice: 'You recant this affidavit or you're going to get 20 years.' So Crittenden recants and gets out, and then I get a new affidavit from him reaffirming what he told me in the first place. He's one of the fellows who got out."

DOs & DON'Ts FOR WHISTLEBLOWERS

Since Rodney Stich has the experience, what kind of suggestions would he give to a potential whistleblower?

"No one had better do what I did," Stich stated unequivocally.

"The system is too corrupt. And the checks and balances don't work. There's enough corrupt people in the Justice Department and the federal courts, and they have access to government officials on the state level. So almost anybody can be pretty much destroyed. And with the media so implicated in the cover-up, it's very difficult for any individual. And then the public doesn't really care.

"For instance," Stich continued, "in my naïve thinking 20 years ago, when I came out with the first edition of *Unfriendly Skies*, I thought

that the public wanted to know and that sufficient percentage of the public had enough courage to help. That unfortunately does not work because the public is more interested in trivia, like sports, and those few who do know don't do anything. And things have just got worse. The corruption has got worse in government. And it's so spread-out now that there's virtually no one there to do anything with this corruption. It's up to the public, and you might as well forget it because the public haven't got it."

So do we deserve this because there have been no outcries of outrage?

"I definitely feel that most of this corruption could not exist if it weren't for the illiteracy of the public and their indifference to it all," said Stich. "And as other people have said to me, maybe they deserve what's being done to them. I'm not sure I would disagree with that.

"One thing I've always tried to do is stay very factual. I don't get into any conspiracy theories or any far-out matters. What I'm trying to do is get the person on the street from the state of ignorance—which, incidentally, I was in when I was an airline pilot, like most pilots—and convey to them some of the hard-core corruption that's going on in government that's affecting very tragically many innocent Americans who don't even know they are suffering, because the media again do a good job of keeping the lid on it."

"And it's so spread-out now that there's virtually no one there to do anything with this corruption.

It's up to the public, and you might as well forget it because the public haven't got it."

TWA FLIGHT 800 DISASTER & COVER-UP

There has been plenty of speculation regarding the reasons for the downing of TWA Flight 800. Rodney Stich, as an aviation safety activist and investigator, has gathered his own evidence regarding the whys and wherefores of the crash and the subsequent poorly staged cover-up. He shared his research and conclusions in this interview.

"It's unprecedented in the history of aviation for so much disinformation and cover-up to occur by the NTSB [National Traffic Safety Board] and the Justice Department," said Stich. "In my book *Unfriendly Skies*, I document repeated instances of NTSB cover-up when serious misconduct was involved.

"In TWA Flight 800, there were almost 200 witnesses who reported seeing a missile trail," continued Stich, "including one person whom I call a missile trail expert. This is a helicopter pilot who had taken off from Long Island [New York]. He was facing the ocean just as the missile was going up. He had seen dozens of missiles fired in Vietnam, including missiles fired at him, so he knows what a missile trail looks like. This is how he described it: 'It was a thin missile-trail going up, and the first explosion is a missile type of an explosion, different from a fuel tank explosion.' That was followed by explosions of fuel tanks—a totally different colour."

And this is where it gets interesting, as the 'legend'—a false story concocted by spooks to distract the public from the facts—is created.

"Here's what the FBI says about all these people who saw the missile trail," continued Stich. "They're saying it's fuel that was coming out of the ruptured fuel tanks and ignited. But it's really not a thin pencil trail—it's a massive fireball! And the FBI expects you to believe that.

"And then they got the CIA involved. It's unheard of for the CIA to be involved in an accident investigation. The CIA has an animated video they showed on TV where the plane is going along, and they claim the centre fuel tank blew up and this is what did it."

It sounds like the 'magic bullet' that supposedly killed JFK. This was the famous bullet that did a U-turn inside of Kennedy's body—the 'theory' invented courtesy of Arlen Specter, currently US Senator from Pennsylvania.

"This is even better," said Stich. "The CIA says that the plane then climbed a few thousand feet—*after* the explosion. The NTSB by law has the responsibility to conduct a meaningful investigation. At the NTSB hearing December 8, the FBI notified the NTSB that they were not to allow anybody to testify or make any reference to a missile, according to *Aviation Week & Space Technology* magazine."

Covert operations and criminal politics again take precedence over air safety and passenger security.

"Here we have the CIA and FBI involved and blocking the NTSB," continued Stich. "And one of the possible reasons for the cover-up? The FBI and CIA were involved in negotiating with Afghan rebels. The rebels wanted to give back 30 to 40 surface-to-air missiles to the United States at no charge. In exchange, they wanted the release from federal prison of the son of one of the rebel leaders. He was there on relatively minor drug-related charges. They had evidently over a hundred *Stinger* missiles left over from the Afghan war. They provided serial numbers of the

Stingers that they had, and the serial numbers were confirmed.

"The CIA, FBI and Justice Department were negotiating, and one of the key negotiators was a friend of mine, a former CIA asset, Ron Rewald. Rewald turned over documents to me. While he was in prison he met the man whom he had previously met in Honolulu in 1995. And now the CIA was dragging its feet about the negotiation."

Stich suddenly made a chilling comment: "Maybe they were more interested in the missiles getting in the hands of the terrorists, for all we know. It was known that terrorists were bidding on the missiles."

Now there's a thought to quicken your pulse. What if?

"If a plane was shot down, that would help justify the CIA's existence," said Stich. "It's almost like the Persian Gulf War. When you don't have a credible enemy, you build up Saddam Hussein to make the Pentagon seem worthwhile."

(A parenthetical note... According to author John Loftus, San Francisco, California-based Bechtel Corporation was responsible for building Saddam Hussein's poison gas factory. It's not ironic, then, that the United States continues building "the best enemy money can buy"—as historian/scholar Antony C. Sutton has shown. First it was Hitler's Germany, then the Soviet Union, and more recently there has been a massive technology transfer to Red China. In fact, this strategic build-up of future 'enemies' is part of a long, historical tradition.)

"Here we have hard evidence that missiles were offered to the United States but were rejected, knowing that terrorists would get them. The missiles are out there and they're going to be used eventually," Stich concluded.

"This is far more evidence than the NTSB has used in many air disasters to come up with the most probable cause. And the cover-up by the FBI—the pressure on people—is enough to reflect on the mindset in the FBI."

"In TWA Flight 800, there were almost 200 witnesses who reported seeing a missile trail," continued Stich, "including one person whom I call a missile trail expert."

THE RISE & FALL OF CIA FRONTMAN RON REWALD

So who is this former CIA asset Ronald Rewald? He's an international wheeler-dealer and the subject of another book by Stich, called *Disavow*. "Disavow" means: "Once your cover is blown, you're on your own, pal".

Rewald hobnobbed with the world's movers and shakers, living the lifestyle of the rich and famous. He had a US\$2 million estate in Hawaii. A chauffeured limo took him to work every day, and he even played polo with the Sultan of Brunei—reportedly the richest man in the world.

Nevertheless, Rewald had a dark secret. He was a frontman for the CIA. He was an informant since college when he began spying on 'subversive' organisations like the SDS (Students for a Democratic Society) during the late 1960s and 1970s.

Later, as chairman of BBRDW (Bishop, Baldwin, Rewald Dillingham and Wong)—a CIA front masquerading as a worldwide investment company—Rewald thought he had nothing to fear. But then came the set-up and betrayal.

Today, after spending 10 years in prison as the fall guy for the CIA, Rewald is reportedly still in denial.

According to Stich, BBRDW was a CIA proprietary (a company wholly owned by CIA operatives), started in 1979 and operated and funded by the CIA using many of the same high-level

people who had staffed the Nugan Hand Bank.

Nugan Hand Bank, of course, was the infamous Australia-based money laundry used by the CIA to disburse South East Asian drug revenues.

In *Defrauding America*, Stich writes: "The CIA used BBRDW as an international investment company cover, with 120 employees staffing offices in 16 countries including Hong Kong, India, Indonesia, Taiwan, New Zealand, Singapore, London, Paris, Stockholm, Brazil and Chile. CIA personnel opened and operated these far-flung offices."

When his cover was blown by a Honolulu reporter, Rewald never saw it coming. As he'd been working for the CIA since his college days, he just naturally assumed that the CIA takes care of its own. Rewald was wrong.

Disavow, by Rodney Stich and T. Conan Russell, should be required reading for every person who's even thinking about working for any of the so-called 'intelligence' agencies (CIA, DIA, NSA, FBI, ONI, etc.). Just as there is no honour among thieves, there is even less among 'spooks'—the spies of the world.

Disavow deals with global *realpolitik*, the important business of state: making drug deals, laundering money, buying elections—all the professional expertise for which the CIA is absolutely unparalleled anywhere on Earth.

Ronald Rewald found out the hard way. If he ever writes his autobiography, he should call it "I was a Chump for the CIA".

OCTOBER SURPRISE COVER-UP

Yes, Virginia; there really was an "October Surprise", and the cover-up continues even now—typically dismissed or ignored by the global mega-media cartel.

An entire chapter in *Defrauding America* covers this crime, scandal and cover-up. The evidence is clear. A gross and heretofore unpunished violation of the US Constitution occurred when George Bush tried to manipulate the Iran hostage crisis so that Ronald Reagan would win the presidential election over President Jimmy Carter.

Simply put, the intent of the scheme was to bring about the defeat of President Carter and elect Reagan. The Reagan-Bush team promised the Iranians billions of dollars of US military equipment and \$40 million in bribes in exchange for freeing the hostages after the election of 1980.

One of Stich's informants, Gunther Russbacher, verified these facts. He was the BAC-111 and SR-71 pilot who flew George Bush to make the deal with the Iranians in Paris.

Stich writes: "The establishment media sought to discredit the CIA whistleblowers who could prove the existence of the October Surprise operation..."

"The evidence supporting the October Surprise charges required impeaching President George Bush and filing criminal charges against key officials in the executive, legislative and judicial branches of the federal government. Never in the history of the United States was there such a serious criminal conspiracy inflicted upon the US by people in control of the White House..."

IRAN-CONTRA & OLIVER NORTH

Was CIA asset and drug kingpin Oliver North of the US National Security Council rewarded for his silence with a national radio show in America? The facts speak for themselves.

Former pilot trainer and whistleblower Terry Reed, co-author of *Compromised*, states unequivocally that his CIA handler was Oliver North, who used the pseudonym "John Cathey".

"The ugly side of the Contra connection was carefully kept from the American public by the establishment media and Congress," writes Stich. "Oliver North and others involved sought to place a humanitarian cloak over their activities with the Contras."

They claimed US involvement in Nicaragua was humanitarian by helping an oppressed people fight communism. But the CIA, representing the American people, traded arms for drugs. Aircraft carrying arms from the United States to Central America often returned with the drugs that were used to pay for the arms."

"It wasn't only the Contras to whom the CIA furnished arms," Stich explains. "The CIA, joined by Israel, arms merchants and others, were selling and delivering arms to the opposition Sandinistas. One CIA operative said to me: 'How else could we keep the fighting going?'"

CIA LIES & DENIALS

According to Stich in *Defrauding America*: "The CIA has hundreds of dummy corporations in the United States...in the form of proprietaries, fronts and cooperating assets. These include...law firms; financial companies such as banks and bond brokerage houses; insurance companies; and airlines..."

"It becomes very easy for the CIA to deny blame for their acts. They simply deny any knowledge of what the front-company or contract agent is doing, in addition to their standard practice of lying. There is no danger to this practice, since Justice Department officials protect their lying and their corrupt operations, and most of the mainstream media also covers for them as well as members of Congress."

Case in point? Here's a classic: an Associated Propaganda, er, I mean, Press article from December 19, 1997. The headline actually reads "CIA clears itself over sales of crack cocaine in US", and the article commences as follows:

"Washington (AP) – The CIA found no evidence that its employees or agents colluded with allies of the Nicaraguan Contra rebels involved in crack cocaine sales in the United States, a senior official said Thursday."

To reiterate Stich: "They simply deny any knowledge of what the front-company or contract agent is doing, in addition to their standard practice of lying."

Then they proclaim "Case closed!"—as CIA asset and strategic writer Gerald Posner would say. "Strategic writer" is evidently an actual job title in the Agency, but it's just a euphemism for "paid liar".

"It wasn't only the Contras to whom the CIA furnished arms.

The CIA, joined by Israel, arms merchants and others, were selling and delivering arms to the opposition Sandinistas.

One CIA operative said to me: 'How else could we keep the fighting going?'"

Continued on page 87

— STAR FIRE —

THE GOLD OF THE GODS

**The true Grail
bloodline originated
with the Anunnaki
gods in southern
Sumeria at least
6,000 years ago and
was sustained by
ingestion of an
alchemical
substance called
'Star Fire'.**

Part 1 of 3

From a lecture presented by
Sir Laurence Gardner,
Kt St Gm., KCD, KT St A.

at the 1998 NEXUS Conference held in
Sydney, 25–26 July

Transcript © Sir Laurence Gardner 1998

It is now nearly two years since my book, *Bloodline of the Holy Grail*, was published, and for those of you who have not read this (or have not seen the serialised lecture transcript in NEXUS magazine), the investigation is essentially concerned with the Messianic Bloodline as it has descended through the family of Jesus Christ down to the present day. It is also concerned with comparing the New Testament Gospels with the first-hand historical accounts of the era, as related in both the Roman and Jewish archives. In this regard, it details how the eventual Christian High Church corrupted and manipulated the early records to suit its own political agenda.

Despite the contrived doctrine that Jesus was born of a virgin and was the 'one and only' son of God (definitions that did not feature in the original pre-Roman texts), the New Testament Gospels of Matthew and Luke actually give details of Jesus' descendant lineage from David of Israel and the Kings of Judah. This has led to the one question I have been asked more than any other during the past months. The question (in its various forms) asks quite simply: What was so special about this Bloodline in the first place?

Given that the dynastic succession from Jesus has been expressly prominent in sovereign and political affairs through 2,000 years—with the family constantly supporting constitutional democracy against control by the Church establishment—its status rests upon the fact that Jesus was a lineal descendant of King David.

But, what was it that made the line of David so important, and so different from any other? It was this very question which set me on the trail for my next book, *Genesis of the Grail Kings*, which tells the story of the Messianic line from the very beginning.

The Bible explains that the Bloodline story began with Adam and Eve, from whose third son, Seth, evolved a line which progressed through Methuselah and Noah, and eventually to Abraham who became the Great Patriarch of the Hebrew nation. It then relates that Abraham brought his family westwards out of Mesopotamia (present-day Iraq) to the land of Canaan (or Palestine), from where some of his descendants moved into Egypt. After a few generations they moved back into Canaan where, in time, the eventual David of Bethlehem became King of the newly defined Kingdom of Israel.

If viewed as it is presented in the scriptures, this is a fascinating saga; but there is nothing anywhere to indicate why the ancestral line of David and his heirs was in any way special. In fact, quite the reverse is the case. His ancestors are portrayed as a succession of wandering territory-seekers who are seen to be of no particular significance until the time of King David. Their biblical history bears no comparison to, say, the contemporary Pharaohs of ancient Egypt. Their significance, we are told, comes from the fact that (from the time of Abraham) they were designated as 'God's chosen people'. But even this leaves us wondering, because, according to the scriptures, their God led them through nothing but a succession of famines, wars and general hardship—and, on the face of it, these early Hebrews do not appear to have been too bright!

We are faced, therefore, with a couple of possibilities. Either David was not of this Abraham succession at all, and was simply grafted into the list by later writers. Or maybe we have been presented with a very corrupted version of the family's early history—a version that was specifically designed to uphold the emergent Jewish faith, rather than to represent historical fact.

In consideration of this, I was reminded of precisely what I had found with the New Testament. The Gospel texts that have been in the public domain for centuries bear little relation to the first-hand accounts of the era. The New Testament, as we know it, was compiled by the 4th-century bishops to support the newly contrived Christian belief. But,

what if the Jewish scribes had previously done exactly the same thing?

Clearly, I had to get back to the more ancient writings in order to find any anomalies. The problem was that, even if this were possible, the earliest Hebrew writings (which were rehashed many centuries later) were themselves only written between the 6th and the 1st centuries BC, so they were not likely to be that authentic in their telling of history from thousands of years before. Indeed, it was plain that this would be the case, because when these books were first written their express purpose was to convey a history which upheld the principles of the Jewish faith—a faith that did not emerge until well into the ancestral story.

Given that the first group of these books was written while the Jews were held captive in Mesopotamian Babylon in the 6th century BC, it is apparent that Babylon was where the original records were then held. In fact, from the time of Adam, through some 19 said generations down to Abraham, the whole of Old Testament patriarchal history was Mesopotamian. More specifically, the history was from Sumer in southern Mesopotamia, where the ancient Sumerians did indeed refer to the grasslands of the Euphrates delta as the *Eden*.

When researching for *Bloodline of the Holy Grail*, I found that good sources for some background information were the various Gospels and texts that were not selected for inclusion in the canonical New Testament. Perhaps, I thought, the same might apply to the Old Testament. The books of Enoch and Jubilees, for example, were among those not included.

A further book, to which attention is specifically drawn in the Old Testament books of Joshua and Samuel, is the Book of Jasher. But despite its apparent importance to the Hebrew writers, it was not included in the final selection.

Two other works are also cited in the Bible. The Book of Numbers draws our attention to the Book of The Wars of Jehovah. And in the Book of Isaiah we are directed towards the Book of the Lord.

What are these books? Where are these books? They are all mentioned in the Bible (which means they all pre-date the Old Testament), and they are all cited as being important. So, why did the editors see fit to exclude them when the selection was made?

In pursuing an answer to this question and in studying the substance of the Old Testament prior to its corruption, one fact which becomes increasingly clear is that in English-language Bibles the definition 'Lord' is used in a general context, but in earlier texts a positive distinction is drawn between 'Jehovah' and 'the Lord'.

It has often been wondered why the biblical God of the Hebrews led them through trials and tribulations, floods and disasters, when (from time to time) he appears to have performed with a quite contrary and merciful personality. The answer is that, although now seemingly embraced as 'the One God' by the Jewish and Christian churches, there was originally a distinct difference between the figures of Jehovah and the Lord. They were, in fact, quite separate deities. The god referred to as 'Jehovah' was traditionally a storm god, a god of wrath and vengeance, whereas the god referred to as 'the Lord' was a god of fertility and wisdom.

So, what was the name given to the Lord in the early writings? It was, quite simply, the prevailing Hebrew word for 'Lord', and the word was 'Adon'. As for the apparent personal name of Jehovah, this was not used in the early days, and even the Bible tells that the God of Abraham was called 'El Shaddai', which means 'Lofty Mountain'.

The apparent name 'Jehovah' came from the original Hebrew stem *YHWH*, which meant 'I am that I am'—said to be a statement made by God to Moses on Mount Sinai, hundreds of years after the time of Abraham. 'Jehovah' was therefore not a name at all, and early texts refer simply to 'El Shaddai' and to his opposing counterpart, 'Adon'.

To the Canaanites, these gods were respectively called 'El Elyon' and 'Baal'—which meant precisely the same things ('Lofty Mountain' and 'Lord').

In our modern Bibles, the definitions 'God' and 'Lord' are used and intermixed throughout, as if they were one and the same character, but originally they were not. One was a vengeful god (a people-hater), and the other was a social god (a people-supporter), and they each had wives, sons and daughters.

The old writings tell us that throughout the patriarchal era the Israelites endeavoured to support Adon, the Lord, but at every turn El Shaddai (the storm god, Jehovah) retaliated with floods, tempests, famines and destruction. Even at the very last (around 600 BC), the Bible explains that Jerusalem was overthrown at Jehovah's bidding and tens of thousands of Jews were taken into Babylonian captivity

simply because their King (a descendant of King David) had erected altars in veneration of Baal, the Adon.

It was during the course of this captivity that the Israelites weakened and finally conceded. They decided to succumb to the 'God of Wrath', and developed a new religion out of sheer fear of his retribution. It was at this time that the name of Jehovah first appeared—and this was only 500 years before the time of Jesus.

Subsequently, the Christian Church took Jehovah on board as well, calling him simply 'God'—and all the hitherto social concepts of the Adon were totally discarded. The two religions were henceforth both faiths of fear. Even today, their followers are classified as 'God-fearing'.

So, where does that leave us? It leaves us knowing that within an overall pantheon of gods and goddesses (many of whom are actually named in the Bible), there were two predominant and opposing gods. In different cultures they have been known as 'El Elyon' and 'Baal'; 'El Shaddai' and 'Adon'; 'Arhiman' and 'Mazda'; 'Jehovah' and 'Lord'; 'God' and 'Father'. But these styles are all titular; they are not personal names.

So who precisely were they? To find the answer we have to look no further than where these gods were actually operative, and the old Canaanite texts (discovered in Syria in the 1920s) tell us that their courts were in the Tigris-Euphrates valley in Mesopotamia, in the Sumerian Eden delta of the Persian Gulf.

But what did the ancient Sumerians call these two gods? What were their personal names? We can trace the Sumerian written records back to about 3700 BC, and they tell us that the gods in question were brothers. In Sumer, the storm god who eventually

In our modern Bibles, the definitions 'God' and 'Lord' are used and intermixed throughout, as if they were one and the same character, but originally they were not.

became known as Jehovah was called 'Enlil' or 'Ilu-kur-gal' (meaning 'Ruler of the Mountain'), and his brother, who became Adon, the Lord, was called 'Enki'. This name is really important to our story because 'Enki' means 'Archetype'.

The texts inform us that it was Enlil who brought the Flood; it was Enlil who destroyed Ur and Babylon, and it was Enlil who constantly opposed the education and enlightenment of humankind. Indeed, the early Syrian texts tell us that it was Enlil who obliterated the cities of Sodom and Gomorrah on the Dead Sea—not because they were dens of wickedness, as we are taught, but because they were great centres of wisdom and learning.

It was Enki, on the other hand, who, despite the wrath of his brother, granted the Sumerians access to the Tree of Knowledge and the Tree of Life. It was Enki who set up the escape strategy during the Flood, and it was Enki who passed over the time-honoured Tables of Destiny—the tables of scientific law which became the bedrock of the early mystery schools in Egypt.

Many books talk about the hermetic school of Thutmose III of Egypt, who reigned about 1450 BC. But it is not generally known that the school he originally inherited was the Royal Court of the Dragon. This had been founded by the priests of Mendes in about 2200 BC and was subsequently ratified by the 12th dynasty Queen Sobeknefru.

This sovereign and priestly Order passed from Egypt to the Kings of Jerusalem; to the Black Sea Princes of Scythia and into the Balkans—notably to the Royal House of Hungary, whose King Sigismund reconstituted the Court just 600 years ago. Today it exists as the Imperial and Royal Court of the Dragon Sovereignty, and after some 4,000 years it is the oldest sovereign Court in the world.

But what were the earliest aims and ambitions of the Order back in Pharaonic times? They were to perpetuate and advance the alchemical strength of the Royal Bloodline from Lord Enki, the Archetype.

The kings of the early succession (who reigned in Sumer and Egypt before becoming Kings of Israel) were anointed upon coronation with the fat of the Dragon (the sacred crocodile). This noble beast was referred to in Egypt as the *Messeh* (from which derived the Hebrew verb 'to anoint'), and the kings of this dynastic succession were always referred to as 'Dragons', or 'Messiahs' (meaning 'Anointed Ones').

In times of battle, when the armies of different kingdoms were conjoined, an overall leader was chosen and he was called the 'Great Dragon' (the 'King of Kings')—or, as we better know the name in its old Celtic form, the 'Pendragon'.

One of the interesting items from the archives of the Dragon Court is the origin of the word 'kingship'. It derives from the very earliest of Sumerian culture, wherein 'kingship' was identical with 'kinship'—and 'kin' means 'blood relative'. In its original form, 'kinship' was 'kainship'. And the first King of the Messianic Dragon succession was the biblical Cain (Kain), head of the Sumerian House of Kish.

On recognising this, one can immediately see the first anomaly in the traditional Genesis story, for the historical line to David and Jesus was not from Adam and Eve's son Seth at all. It was from

Eve's son Cain, whose recorded successors (although given little space in the Old Testament) were the first great Kings (or Kains) of Mesopotamia and Egypt.

Two more important features then come to light when reading the Bible again with this knowledge in mind. We all tend to think of Cain as being the first son of Adam and Eve, but he was not. Even the Book of Genesis tells us that he was not, and it confirms how Eve told Adam that Cain's father was the Lord. Who was 'the Lord'? The Lord was Adon, and Adon was Enki. Even outside the Bible, the writings of the Hebrew Talmud and Midrash make it quite plain that Cain was not the son of Adam.

So what else have we been wrongly taught about this particular aspect of history? The Book of Genesis (in its English-translated form) tells us that Cain was 'a tiller of the ground'. But this is not what the original texts say at all. What they say is that Cain had 'dominion over the Earth'—which is a rather different matter when considering his kingly status.

In fact, the Bible translators appear to have had a constant problem with the word 'Earth', often translating it to 'ground', 'clay' or 'dust'. But the early texts actually referred to 'The Earth'. Even in the case of Adam and Eve, the translators got it wrong. The Bible says: 'Male and female he created them, and he called *their* name Adam.' The older writings use the more complete word 'Adama', which means 'of the Earth'. But this did not mean they were made of dirt; it means that they were 'of The Earth'—or, as the Anchor Hebrew Bible explains in absolutely precise terms, they were 'Earthlings'.

There is a lot to be said about the story of Adam and Eve and of how they were the result of clinical cloning. Writers such as Zechariah Sitchin have written at some length in this regard, and my new book delves far more deeply into the subject. I shall not dwell upon this particular aspect now because I want to move more directly into the alchemy of the Messianic Bloodline of the Earthly Dragon Kings. What I will say is that the Sumerian records state that around 6,000 years ago, Adam and Eve (known then as 'Atabba' and 'Ava', and jointly as the 'Adama') were purpose-bred for kingship at the House of Shimti by Enki and his sister-wife Nin-khursag. In Sumerian, the word *Shi-im-ti* meant 'breath-wind-life'.

Adam was certainly not the first man on Earth, but he was the first of the alchemically devised kingly succession. Nin-khursag was called 'Lady of the Embryo' or 'Lady of Life', and she was the surrogate mother for Atabba and Ava who were created from human ova fertilised by the Lord Enki.

It was because of Nin-khursag's title, Lady of Life, that Ava was later given the same title by the Hebrews. Indeed, the name Ava (or Eve) was subsequently said to mean 'Life'. And there is an interesting parallel here, because in Sumerian the distinction 'Lady of Life' was *Nin-ti* (*Nin* meaning 'Lady', and *ti* meaning 'Life'). However, another Sumerian word, *ti* (with the longer pronunciation, 'tee'), meant 'rib'; and it was by virtue of the Hebrews' misunderstanding of the two words, *ti* and *ti*, that Eve also became incorrectly associated with Adam's rib.

Both Enki and Nin-khursag (along with their brother Enlil, the later Jehovah) belonged to a pantheon of gods and goddesses

Indeed, the early Syrian texts tell us that it was Enlil who obliterated the cities of Sodom and Gomorrah on the Dead Sea—not because they were dens of wickedness, as we are taught, but because they were great centres of wisdom and learning.

referred to as the *Anunnaki*, meaning 'Heaven came to Earth'. In fact, the Grand Assembly of the Anunnaki (later called the 'Court of the Elohim') is mentioned in Psalm 82 wherein Jehovah makes his bid for supreme power over the other gods.

According to the Dragon tradition, the importance of Cain was that he was directly produced by Enki and Ava, so his blood was three-quarters Anunnaki. His half-brothers Hevel and Satanael (better known as Abel and Seth) were less than half Anunnaki, being the offspring of Atabba and Ava (Adam and Eve).

Cain's Anunnaki blood was so advanced that it was said that his brother Abel's blood was 'Earthbound' by comparison. Cain, it was said in the scriptures, 'rose far above Abel', so that his brother's blood was swallowed into the ground. But this original description was thoroughly mistranslated for our modern Bible, and we are now told that 'Cain rose up against Abel and spilled his blood upon the ground'. This is not the same thing at all.

We can now progress our story by considering the oldest Grant of Arms in sovereign history—a Grant of Arms which denoted the Messianic Dragon Bloodline for all time. The Sumerians referred to this insignia as the *Gra-al*. Sounds familiar, doesn't it? From biblical history, however, we know it better as the 'Mark of Cain'.

This 'Mark' is portrayed to us by the Church as if it were some form of curse. But, knowing what we now know, the Bible does not actually say this. What it says is that, having got into an argument with Jehovah over a matter of sovereign observance, Cain feared for his life. We are then informed that the Lord placed a mark upon Cain, swearing sevenfold vengeance against his enemies.

No one has ever really understood why Jehovah should decide to protect Cain when it was he who held the grievance against him. But the fact is that Jehovah did not make this decision. Cain's protector was not Jehovah. As stated, the 'Mark' was settled upon Cain by the Lord—and the Lord (the Adon) was Cain's own Father, Enki.

Few people ever think to enquire about the supposed enemies of Cain as defined in Genesis. Who could they possibly have been? Where would they have come from? According to the Bible, only Adam and Eve, with their sons Cain and Abel, existed—and Cain had apparently killed Abel. If we are to accept the text as it stands, there was no one around to be his enemy!

So, what was this Sumerian *Gra-al* which the Bible calls 'the Mark of Cain'? It was an emblem dignified as the 'Cup of the Waters' or the *Rosi-Crucis* (the 'Dew Cup'), and it was identified in all records (including those of Egypt and Phoenicia and in the Hebrew annals) as being an upright, centred red cross within a circle. Throughout the ages it was developed and embellished, but it has always remained essentially the same and is recognised as being the original symbol of the Holy Grail.

Another anomaly is presented soon afterwards in Genesis when we are told that Cain found himself a wife. Who on Earth were her parents if Adam and Eve were the only couple alive? Without confronting this anomaly at all, Genesis then proceeds to list for us the names of Cain's descendants!

It becomes clear from all of this that some very important information has been edited from the Old Testament narrative. Clearly

there were plenty of other people around at the time and it is not difficult to find their stories outside the Bible. Quite apart from the Sumerian annals, even old Hebrew and early Christian texts give us far more information in this regard.

In order to further enhance the succession from Cain, he was married to his half-sister—a pure-bred Anunnaki princess, Luluwa. Her father was Enki and her mother was Lilith, a granddaughter of Enlil. Although not giving the name of Cain's wife, the Bible does name their younger son Enoch, while the Sumerian records cite his elder son and kingly successor, Atûn, who is perhaps better known as King Etana of Kish.

Etana was said to have 'walked with the gods', and to have been fed from the 'Plant of Birth' (or the 'Tree of Life', as it is called in Genesis). Henceforth, the kings of the line were designated as being the twigs of the Tree—and the ancient word for 'twig' was *klone* (clone). In later times this 'Plant' or 'Tree' was redefined as a 'Vine', and so the *Gra-al*, the Vine and the Messianic Bloodline became conjoined as one in the literature of subsequent ages.

By virtue of their contrived breeding, this kingly succession was modelled specifically for leadership, and in all aspects of knowledge, culture, awareness, wisdom and intuition they were highly advanced against their mundane contemporaries. In order to keep their blood as pure as possible, they always married within a close kinship.

**True kingship, it was maintained,
was transferred through the
female, and so kingly marriages
were strategically cemented with
maternal half-sisters or
first cousins.**

It was fully recognised that the prominent gene of the succession was carried within the blood of the mother. Today we call this the 'mitochondrial DNA'. And so was born a tradition inherited by their kingly descendants in Egypt and by the later Celtic rulers of Europe. True kingship, it was maintained, was transferred through the female, and so kingly marriages were strategically cemented with maternal half-sisters or first cousins.

Having reached the point where the Plant of Birth is first mentioned in the records, we are at about 3500 BC; and it is at this point that we begin to learn how the kingly succession was orally fed with bodily supplements from the early days. This practice continued for more than 1,000 years until the nourishment program became wholly scientific and alchemical.

Before getting into the detail of the kingly diet, it is worth considering why it was that the all-important Royal Bloodline which progressed from Cain and his sons was strategically ignored by the Hebrews and the Christian Church in favour of their promoting a parallel junior line from Adam's son Seth. Why was it that the immediate Cainite dynasty was eventually shunned by the fearful disciples of Enlil-Jehovah?

In the Old Testament Book of Genesis, the lines of descent are given from Cain and from his half-brother Seth, but it is of interest to note that through the early generations the names detailed in each list are pretty much the same, although given in a different order: Enoch, Yared, Mahalaleel, Methuselah and Lamech.

In view of this, it has often been suggested that the line from Seth down to Lamech's son Noah was (not very cleverly) contrived by the Bible compilers so as to avoid showing the true descent from Cain to the time of Noah. If this were the case, then something must have occurred during the lifetime of Noah to cause the ancestral story to be veiled by the later writers. The

answer is to be found in the Bible itself.

At that stage in the family's history, the vengeful Jehovah apparently warned Noah and his sons against the ingestion of blood—an edict which became expressly important to the later Jewish way of life. It has long been a customary Jewish practice to hang meat for blood-letting before cooking and consumption.

But, in contrast, the Christian faith is especially concerned with the figurative ingestion of blood. In the Christian tradition it is customary to take the Communion sacrament (the Mass) wherein wine is drunk from the sacred chalice, symbolically representing the blood of Jesus, the lifeblood of the Messianic Vine.

Could it be, perhaps, that the modern Christian custom is an unwitting throw-back to some distant pre-Noah ritual which Jehovah opposed? If so, then since it is known that the chalice is a wholly female symbol which has been emblematic of the womb from the earliest times, might this even have been an extract of menstrual blood? The answer to these questions is 'Yes'. That was precisely the custom, but it was not so unsavoury as it might seem. Indeed, few of us think to enquire about the ultimate sources of many of today's ingested medicines and bodily supplements, and those in the know would often be reluctant to tell us. The Premarin hormone, for example, comes from the urine of pregnant mares, while certain growth hormones and insulin are manufactured from *E. coli*, a faecal bacterium.

The blood extract in question was, in the first instance, not human but from the sacred Anunnaki lunar essence—that of Enki's sister Nin-khursag, the designated Lady of Life. It was defined as the most potent of all life-forces and was venerated as being 'Star Fire'. It was from the womb of Nin-khursag that the kingly line was born, and it was with her blood, the divine Star Fire, that the Dragon succession was supplementally fed.

In ancient Egypt, Nin-khursag was called 'Isis', and by either name she was the ultimate Mother of the Messianic line, for hers was the matriarchal gene which constituted the 'Beginning', the 'Genesis', or, as the Greeks identified it, the *Genesis*.

It is worth reminding ourselves, then, that the biblical edict to abstain from blood came not from Enki the Wise but from Enlil-Jehovah—the God of Wrath who had instigated the Flood, had wrought havoc in Ur and Babylon, and had endeavoured to deceive Adam by saying that he would die if he ate from the Tree of Knowledge. This was not a god who liked people, and the Sumerian records are very clear in this regard. Hence, if he forbade the taking of blood, this was not likely to have been an edict for the benefit of Noah and his descendants—it was most probably to their detriment.

In strict terms the original Star Fire was the lunar essence of the Goddess, but, even in an everyday mundane environment, menstruum contains the most valuable endocrinal secretions, especially those of the pineal and pituitary glands. The brain's pineal gland in particular was directly associated with the Tree of Life, for this tiny gland was said to secrete the very essence of active longevity, called *soma*, or, as the Greeks called it, *ambrosia*.

In mystic circles, the menstrual 'flow-er' ('she who flows') has long been the designated 'flower' and is represented as a lily or a lotus. Indeed, the definition 'flow-er' is the very root of our modern word 'flower'. In ancient Sumer, the key females of the

Dragon succession were all venerated as lilies, having such names as Lili, Luluwa, Lilith, Lilutu and Lillette.

In pictorial representation, the Messianic Dragon bore little relation to the winged, fire-breathing beast of later Western mythology. It was, in essence, a large-jawed serpent with four legs, very much like a crocodile or a monitor. This was the sacred *Messeh* whose name was 'Draco'. Draco was a divine emblem of the Egyptian Pharaohs, a symbol of the Egyptian Therapeutate, of the Essenes at Qumran, and was the *Bistea Neptunis* (the sea serpent) of the descendant Merovingian Fisher-Kings in Europe.

In the old Hebrew Bibles, all references to serpents are made by use of the word *nahash* (from the stem *NHSH*); but this usage does not relate to serpents in the way that we would know them—that is, as venomous snakes. It relates to serpents in their traditional capacity as bringers of wisdom and enlightenment, for the word *nahash* actually means 'to decipher' or 'to find out'.

Serpents, in one form or another, were always associated with wisdom and healing, and the Trees of Life and Knowledge are customarily identified with serpents. Indeed, the insignia of many of today's medical associations is precisely this image of a serpent coiled around the Plant of Birth (Tree of Life)—a depiction shown in the clay reliefs of ancient Sumer to be Enki's personal emblem.

In strict terms the original Star Fire was the lunar essence of the Goddess, but, even in an everyday mundane environment, menstruum contains the most valuable endocrinal secretions, especially those of the pineal and pituitary glands.

Interestingly, though, another common emblem for medical relief organisations depicts two coiled serpents, spiralling around the winged caduceus of Hermes the magician. In these instances the true symbolism of the Star Fire ritual is conveyed, and this symbol can be traced back to the very origins of the alchemical mystery schools and gnostic institutions.

The records explain that the central staff and entwined serpents represent the spinal cord and the sensory nervous system. The two uppermost wings signify the brain's lateral ven-

tricular structures. Between these wings, above the spinal column, is shown the small central node of the pineal gland.

The combination of the central pineal and its lateral wings has long been referred to as the 'Swan', and in Grail lore (as in some yogic circles) the Swan is emblematic of the fully enlightened being. This is the ultimate realm of consciousness achieved by the mediaeval Knights of the Swan, as epitomised by such chivalric figures as Perceval and Lohengrin.

Most of you are probably quite familiar with the functions of the pineal and other glands of the endocrinal system. But for those who are perhaps not, the pineal is a very small gland, shaped like a pine cone and about the size of a grain of corn. It is centrally situated within the brain, although outside the ventricles and not forming a part of the brain-matter as such.

The pineal gland was thought by the 17th-century French optical scientist René Descartes to be the seat of the soul—the point at which the mind and body are conjoined. The ancient Greeks considered it likewise, and in the 4th century BC Herophilus described the pineal as an organ which regulated the flow of thought. This gland has long intrigued anatomists because, while the rest of the brain is 'double', the pineal has no counterpart.

In the days of ancient Sumer, the priests of Anu (the father of Enlil and Enki) perfected and elaborated a ramifying medical science of living substances, with menstrual Star Fire being an

essential source component. In the first instance, this was pure Anunnaki lunar essence called 'Gold of the Gods', and it was fed only to the Kings and Queens of the Dragon succession. Later, however, in Egypt and Mediterranean, menstrual Star Fire was ritually collected from sacred virgin priestesses who were venerated as 'Scarlet Women'. Indeed, the very word 'ritual' stems from this practice, and from the word *ritu*—which defined the sacred ceremony of the 'Red Gold'.

Endocrinal supplements are, of course, still used by today's organotherapy establishment, but their inherent secretions (such as melatonin and serotonin) are obtained from the desiccated glands of dead animals and they lack the truly important elements which exist only in live human glandular manufacture.

In the fire symbolism of ancient alchemy, the colour 'red' is synonymous with the metal 'gold'. In some traditions (including the Indian tantras), 'red' is also identifiable with 'black'. Hence, the goddess Kali is said to be both 'red' and 'black'. The original heritage of Kali was, however, Sumerian, and she was said to be Kalimâth, the sister of Cain's wife Luluwa.

Kali was a primary princess of the Dragon House, and from her Star Fire association she became the goddess of time, seasons, periods and cycles. Because of this, her name was the root of the word 'calendar' (*kalindar*), which is concerned with the divisions of seasonal time.

In the early days, therefore, the metals of the alchemists were not common metals but living essences, and the ancient mysteries were of a physical, not a metaphysical, nature. Indeed, the very word 'secret' has its origin in the hidden knowledge of glandular secretions. Truth was the *ritu* (the 'redness' or 'blackness'), and from the word *ritu* stems not only ritual but also the words 'rite', 'root' and 'red'. The *ritu*, it was said, reveals itself as physical matter in the form of the purest and most noble of all metals: gold. Hence, gold was deemed an 'ultimate truth'.

Just as the word 'secret' has its origin in the translation of an ancient word, so too do other related words have their similar bases. In ancient Egypt, the word *Amen* was used to signify something hidden or concealed. The word 'occult' meant pretty much the same ('hidden from view'), and yet today we use 'Amen' to conclude hymns, while something 'occult' is deemed sinister. In real terms, however, they both relate to the word 'secret', and all three words were, at one time or another, connected with the mystic science of endocrinal secretions.

Since Kali was associated with 'black' (being 'black but beautiful'), the English word 'coal' (denoting 'that which is black') stems also from her name via the intermediate word *kol*. In the Hebrew tradition, *Bath-Kol* (a Kali counterpart) was called the 'Daughter of the Voice', and the voice was said to originate during a female's puberty. Hence, the womb was associated with the voice, and Star Fire was said to be the oracular 'Word of the Womb'. The womb was, therefore, itself the 'utterer', or the 'uterus'.

The 'Scarlet Women' were so called because of their being a direct source of the priestly Star Fire. They were known in Greek as the *Hierodulai* ('Sacred Women')—a word later transformed (via mediaeval French into English) to 'harlot'. In the early Germanic tongue, they were known as *Horés*—which was later

Anglicised to 'whores'. However, the word originally meant, quite simply, 'Beloved Ones'. As pointed out in good etymological dictionaries, these words were descriptions of high veneration and were never interchangeable with such words as 'prostitute' or 'adulteress'. Their now common association was, in fact, a wholly contrived strategy of the mediaeval Roman Church in its bid to denigrate the noble status of the sacred priestess.

The withdrawal of knowledge of the genuine Star Fire tradition from the public domain occurred when the science of the early adepts and later Gnostics (the true pre-Christian Christians) was stifled by the forgers of historic Christianity. A certain amount of the original *gnosis* (or knowledge) is preserved in Talmudic and rabbinical lore, but, generally speaking, the mainstream Jews and Christians did all in their power to distort and destroy all traces of the ancient art.

In addition to being the 'Gold of the Gods', the Anunnaki menstruum was also called the 'Vehicle of Light', being the ultimate source of manifestation, and in this regard it was directly equated with the mystical 'Waters of Creation'—the flow of eternal wisdom. It was for this reason that the *Rosi-Crucis* (the Dew Cup, or Cup of the Waters identified as a red cross within a circle) became the Mark of Cain, and the subsequent emblem of the kingly succession.

It was said that the Light remained quite dormant in a spiritual-ly unawakened person but that it could be awakened and motivated

by the spiritual energy of self-will, and by constant self-enquiry. This is not an obvious mental process, but a truly thought-free consciousness—a formless plane of pure Being.

Continued in the next issue...

The withdrawal of knowledge of the genuine Star Fire tradition from the public domain occurred when the science of the early adepts and later Gnostics (the true pre-Christian Christians) was stifled by the forgers of historic Christianity.

About the Speaker:

Sir Laurence Gardner, Kt St Gm., KCD, KT St A., is an internationally known sovereign and chivalric genealogist. He holds the position of Prior of the Celtic Church of the Sacred Kindred of Saint Columba, and is distinguished as Le Chevalier Labhrán de Saint Germain and Preceptor of the Knights Templars of Saint Anthony. Sir Laurence is also Presidential Attaché to the European Council of Princes (a constitutional advisory body established in 1946), and Chancellor of the Imperial and Royal Court of the Dragon Sovereignty. He is formally attached to the Noble Household Guard of the Royal House of Stewart, founded at St Germain-en-Laye in 1692, and is the Jacobite Historiographer Royal by Appointment.

Editor's Notes:

- Correspondence for Sir Laurence Gardner should be sent to him care of his postal address: Columba House, PO Box 20, Tiverton EX16 5YP, United Kingdom.
- Sir Laurence Gardner's first book, *Bloodline of the Holy Grail: The Hidden Lineage of Jesus Revealed*, was published by Element Books in 1996 (ISBN 1-85230-870-2 h/c), and is available in paperback (ISBN 1-86204-152-0), distributed widely by Penguin Books. It was reviewed in NEXUS 4/01. The second book in his Grail bloodline trilogy is *Genesis of the Grail Kings: The Pendragon Legacy of Adam and Eve*, which is due to be published by Bantam-Transworld in the first quarter of 1999.
- Video and audio tapes of Sir Laurence Gardner's presentation at the 1998 NEXUS Conference in Sydney will be available soon. Contact your nearest office for details or, better still, e-mail us at nexus@peg.apc.org for a quicker reply.

Hans Coler's Free-Energy Generators

The low-technology magnet-based devices developed by German inventor Hans Coler in the 1920s are worthy of redevelopment by 'free-energy' researchers today.

by Robert Nelson © 1998

Rex Research
PO Box 19250
Jean, NV 89019, USA

Immediately after World War II, Allied technical teams plundered all the scientific data they could find in Germany. Much of what they learned remains classified to this day. One most remarkable exception to this secrecy is the declassified British Intelligence Objectives Subcommittee (BIOS) Final Report No. 1043, Item 32: "The Invention of Hans Coler Relating to an Alleged New Source of Power" (see extract below). Coler was interviewed by R. Hurst (Ministry of Supply) and Capt. R. Sandberg (Norwegian Army):

[Naval Captain] Hans Coler is the inventor of two devices by which it is alleged that electric energy may be derived without a chemical or mechanical source of power. Since an official interest was taken in his inventions by the German Admiralty it was felt that an investigation was warranted, although normally it would be considered that such a claim could only be fraudulent... Accordingly, Coler was visited and interrogated. He proved to be cooperative and willing to discuss all details of his devices, and consented to build and put into operation a small model of the so-called *Magnetstromapparat* [Magnet Current Apparatus]...

With this device, consisting only of permanent magnets, copper coils and condensers in a static arrangement, he showed that he could obtain a tension of 450 mv for several hours... One model is said to have worked for three months locked in a room in the Norwegian Legation in Berlin in 1933... The greatest tension obtained was 12 volts.

Coler also invented another device called the *Stromzeuger* (Current Generator). He claimed that "with an input of a few watts from a dry battery, an output of 6 kW could be obtained indefinitely". The last and largest model which Coler built was destroyed by a bomb in 1945, but "Coler expressed his willingness to construct it, given the materials, the time required being about three weeks". The public version of the BIOS report does not state whether or not this was done. However, Bill Lehr (d. 1996) informed this writer that a close friend of his once saw a *Stromzeuger* in operation in the offices of MI5 in London, and a copy of the original BIOS report which is over 200 pages in length. The declassified report is a mere 30 pages long.

Hurst and Sandberg also interviewed Dr F. Modersohn who had collaborated with Coler and financed his research for 10 years. He corroborated every detail of Coler's story. The *Magnetstromapparat* was developed by Coler and von Unruh (who had died by 1945), and they were assisted by Franz Haid of Siemens-Schukert. Haid also built a working model which was seen in operation by Dr Kurt Mie (Technical College of Berlin), and Herr Fehr who was the assistant of the renowned scientist Fritz Haber. The *Magnetstromapparat* was described thus:

This device consists of six permanent magnets wound in a special way so that the circuit includes the magnet itself as well as the winding (fig. 1). These six magnet-coils are arranged in a hexagon and connected as shown in the diagram (figs. 2 & 3) in a circuit which includes two small condensers, a switch and a pair of solenoid coils, one sliding inside the other. To bring the device into operation the switch is left open, the magnets are moved slightly apart, and the sliding coil set into various positions with a wait of several minutes between adjustments. The magnets are then separated still further and the coils moved again. This process is repeated until at a critical separation an indication appears on the voltmeter. The switch is now closed, and the procedure is continued more slowly. The tension then builds up gradually to a maximum and should then remain indefinitely. The

greatest tension obtained was stated to be 12 volts...

In our presence...Coler built an apparatus as shown in figures 1-3. It is to be noted that *some of the magnets are wound in a clockwise direction looking at the N-pole (called "left"), and others in an anti-clockwise direction (called "right")*. The magnets were selected to be as nearly equal in strength as possible, and the resistance of the magnet-coil combination was checked after winding to see that this also was uniform (about 0.33 ohm)... The physical arrangement was as shown in fig. 2... A mechanical arrangement of sliders and cranks for separating the magnets evenly all around was made up...

When the magnets were at a separation of about 7 millimetres, the first small deflection was noted. The switch was closed, and by slow adjustment of the sliding coil and by increasing the separation of the magnets to just over 8 mm the tension was raised to 250 millivolts. This was maintained for another three hours when a soldered tag became disconnected and the meter slowly dropped back to zero. Soldering up the broken connection did not restore the tension. The magnets were closed up and left overnight, and the same procedure for adjustment was repeated on 2-7-46. After about three hours a deflection of 60 mv was obtained; this was maintained for more than 30 minutes, but then decreased to zero when further adjustments were tried.

During all this work, the model was completely open and nothing could be hidden in it. The breadboard and meter could be picked up and moved round the room, tilted or turned, without effect.

The apparatus would appear to be too crude to act as a receiver of broadcast energy or to operate by induction from the mains (the nearest cable was six feet away), and the result must for the moment be regarded as inexplicable...

[Coler was of the opinion that] ferromagnetism was an oscillating phenomenon, of frequency about 180 kilohertz. This oscillation took place in the magnetic circuit of the apparatus, and induced in the electrical circuit the frequency which of course depended on the value of the components used. These two phenomena interacted and gradually built up the tension... Coler stated that the strength of the magnets did not decrease during the use of the apparatus, and suggested that he was tapping a new sort of energy hitherto unknown, called *raumenergie* (space energy).

It was judged that Coler was an honest experimenter and not a fraud... The result obtained was genuine insofar as could be tested with the facilities available, but no attempt has yet been made to find an explanation of the phenomenon...

Kloss tried to interest the German Government in the invention, but his request was refused because it was a "perpetual motion machine".

The *Stromzeuger* was invented in 1925, at which time Coler showed a 10-watt model to Prof. Kloss in Berlin. Kloss tried to interest the

German Government in the invention, but his request was refused (as was Coler's patent application) because it was a "perpetual motion machine". The model was also seen by Prof. Schumann (of terrestrial resonance fame), Prof. Bragstad (Trondheim), and Prof. Knudsen (Copenhagen). Kloss and Schumann wrote reports explaining the physics of its operation, which apparently amplified the Barkhausen effect to a useful level. The *Stromzeuger* was described in the BIOS report as follows:

This device consists of an arrangement of magnets, flat coils and copper plates with a primary circuit energised by a small dry battery. The output from the secondary was used to light a bank of lamps, and was claimed to be many times the original input and to continue indefinitely...

Coler and von Unruh constructed a 70-watt model of the

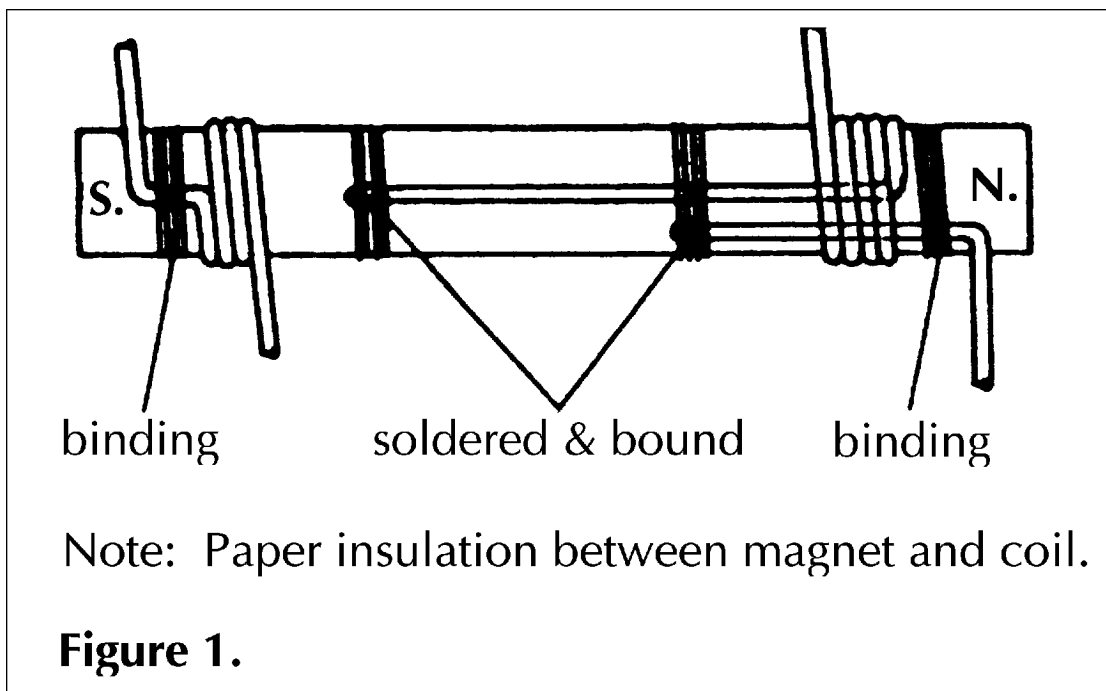

Stromzeuger in 1933 and demonstrated it to Dr F. Modersohn who subsequently financed the development of the invention and established the Coler GmbH for the purpose.

In 1937, Coler built a 6 kW version of the *Stromzeuger*. In 1942, Modersohn demonstrated the device to the Research Department of the German Navy, which intervened and supplied them with materials, meters and tools. Thereafter the research was directed by Oberbaurat (Naval Construction Chief) Seysen, who assigned Dr H. Frolich to assist Coler for several months. The operation of the newly developed apparatus turned out to be more complicated than they had first thought, but progress was made. The large *Stromzeuger* was destroyed by a bomb which struck Coler's house in Kolberg (Pomerania) in 1945. Coler had been powering his house with the unit for three years.

Hurst and Sandberg gave a summary account of the *Stromzeuger* in their report:

The basic principle is that *an electron is to be regarded not only as a negatively charged particle but also as a South magnetic pole.*

The basic element is that of an open secondary circuit, capacity loaded, inductively coupled to a primary circuit. The novel feature is that the capacities are connected to the secondary core through permanent magnets, as shown in figure 4.

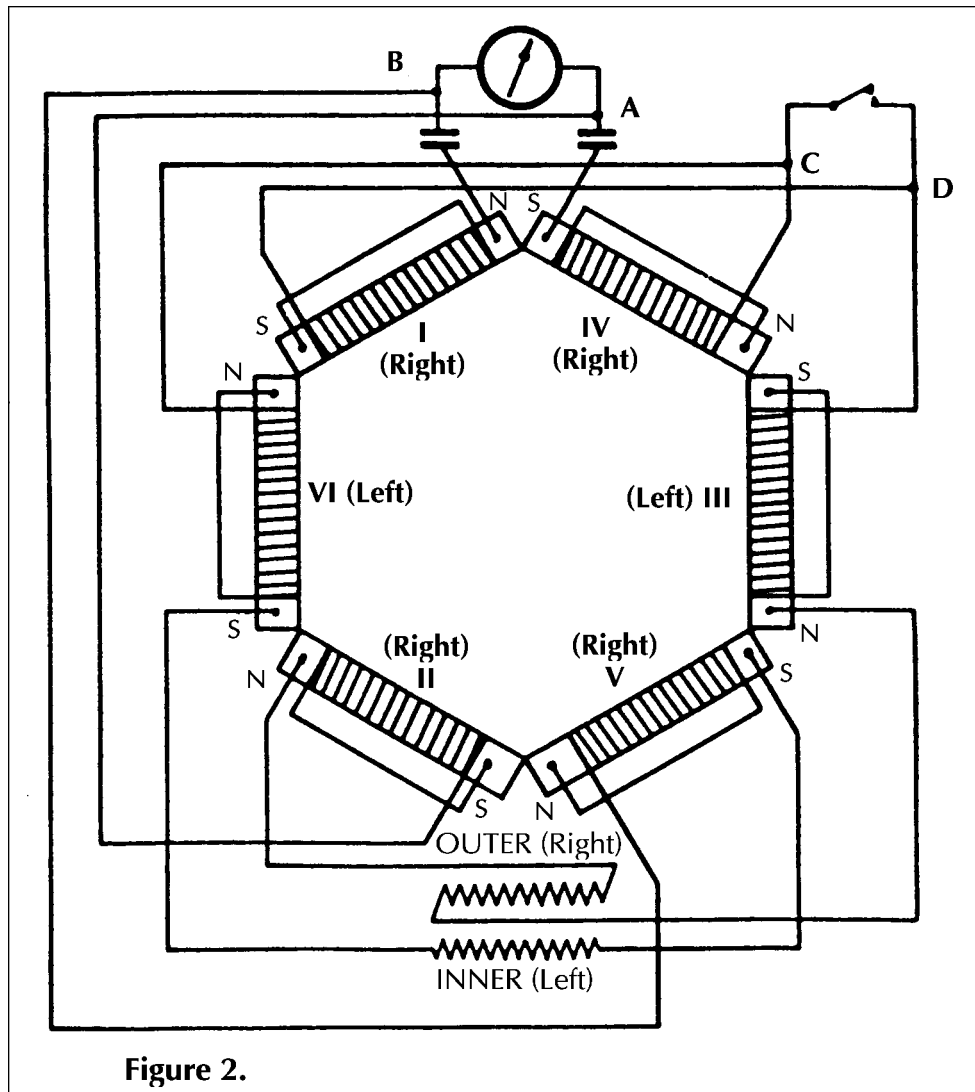

Figure 2.

It is claimed that, on switching on the primary circuit, "separation of charges" takes place, i.e., Magnet 1 becomes positively charged and Magnet 2 becomes negatively charged, and that these charges are "magnetically polarised" when they are formed, owing to the presence of the magnets. On switching off the primary circuit, a "reversing current" flows in the secondary, but the magnets "do not exert a polarising effect on this reversal".

Two of these basic elements are now placed together, making a double system or stage with the plates close together in parallel planes, as shown in figure 5. The secondary windings are both exactly equal and wound in a direction such that, on switching on the primary coil, the electrons in the secondary coil flow from P_1 to P_2 [P = Plate] and F_1 to F_2 [F = Flat Spool].

It is then stated that system $F_1 - F_2$ merely has an inducing effect, and the useful current comes into existence in the system $P_1 - P_2$.

A single stage cannot be effective, but two stages connected so that the numbers of effective North and South poles are equal will provide a basic working arrangement. More double stages can then be added to provide higher outputs.

It is then stated that as well as the normal electrons flowing from the battery and from induction when the circuit is opened or closed, "space electrons" flow from "repelling spaces" to "attracting spaces" between the plates...

Professors M. Kloss and R. Franke (Technical College of Berlin) tested the *Stromzeuger* in March 1926. Their report was included in BIOS Report No. 1043:

The apparatus...consists of: a double-row system of copper plates, a double-row system of flat spools, and a system of electromagnets to whose cores silver wires are attached and through which branch currents of the plate-system are conducted. For each of the three systems a three-part accumulator battery of 6 volts/6.5 ampere-hours capacity is provided. The plate circuit and the spool circuit are parallel so that the two batteries appertaining thereto can also be replaced by a single battery. This was ascertained...by switching off the one battery while the apparatus was working.

When asked why two batteries were used at all, Capt. Coler declared that for starting the apparatus a double

battery is necessary to get a second charge-impetus after exciting with the one battery, and this for releasing the peculiar character of the apparatus. A test...confirmed this assertion in as much as the mechanism could not be started with the single battery; on the contrary, the "adjustment" of the mechanism got disturbed.

Current-indicators are built into each of the three circuits mentioned, as well as volt-meters, behind some switch resistances necessary for the "adjustment". Between the open ends of the two plate-and-spool systems there are the terminal clamps for the effective circuit, for whose loading three bulbs of 8 volts are provided. The apparatus was then put into action and, above all, the load was tested with the aid of the built-in instruments; that is, on being loaded with [two to three] lamps...

The consumption of energy in the external circuit is greater than the energy taken from the batteries. According to the circuit...the magnet-exciting circuit is fed by a special battery, completely separated from the other two circuits. Consequently, a direct comparison of efficiency and consumption of the apparatus would mean that only the sum of current of the plate circuit and of the spool circuit would count...

Figure 3.

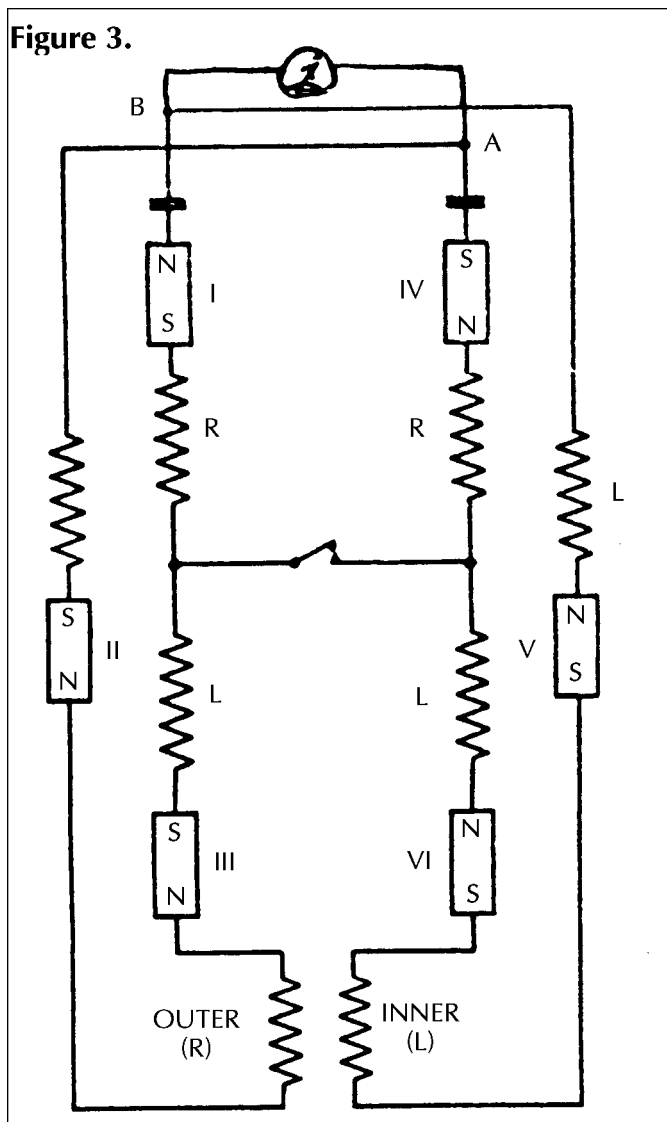

The reception of current from the two batteries in this case...was 1.7 watts, while the consumption of the bulbs amounted to about 8 watts. Especially striking in this connection is the considerably higher current-power in the bulb circuit, being about 12 times bigger than the current coming from the two batteries...

Professor W. O. Schumann (Munich) also tested the *Stromzeuger* in 1926. His six-page analysis was included in an appendix of the BIOS Report:

The apparatus in question principally consists of two parallel-connected spools which, being bifilarly wound in a special way, are magnetically linked together. One of these spools is composed of copper sheets (the spool is called "plate spool"); the other one of a number of thin parallel-connected isolated wires (called "spool winding"), running parallel at small intervals to the plates. Both spools can be fed by separate batteries; at least two batteries are necessary to put the spools to work.

The spools are arranged in two halves each, according to the bifilar winding system. The batteries are attached to the starting points, and the current-receivers to the parallel-connected ends. Intercommunications are connected between parallel windings of the two halves of the plate spool which contain iron rods with silver connections. These rods are magnetised by a special battery through applied windings (called "exciter windings").

According to the statement of the inventor, the production of energy principally takes place in these iron rods, and the winding of the spools plays an important part in it... (The form of the spool is a long, small rectangle.)

The inventor stated that the apparatus in its installation was very sensitive, especially with regard to the magnetic conditions of the iron cores, and that a wrong treatment [internal measurements] would cause interferences which would be wearisome and very difficult to be eliminated.

The exciter winding is electrically completely separated from the other windings...

Installed in the apparatus were three current meters for the currents from the three batteries, and, furthermore, current and volt meters...for the current receivers. One and two bulbs respectively were employed for this purpose...

As a striking fact it should be mentioned that the spool circuit, having been at first always switched on alone, received a current of 104 mA. As soon as plates and exciter circuit additionally and simultaneously were turned on, as, according to the inventor, the apparatus demands it, the current in the spool circuit [came] down to about 27 mA...

After the present examination, carried through as carefully as [possible], I must surmise that we have to face the exploitation of a new source of energy whose further developments can be of an immense importance... I believe that a further development of the apparatus...will prove justified and of great importance.

In 1943, Hans Coler and Dr Heinz Frohlich made a report to the Research Department of the Admiralty (OKM) in Berlin, in which they described the *Stromzeuger*:

The apparatus consists of three principal circuits which are interwound and intercoupled in a peculiar way. Some of these are divided again into single subsidiary circuits

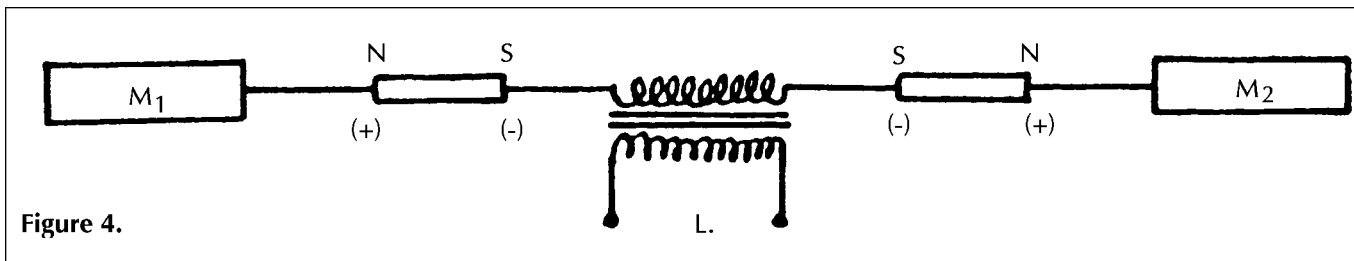

Figure 4.

which evidently have all to be brought into resonance with one another.

The principal circuits (called the "anchor") in which the energy gain probably occurs, consist of metal plates between which transformer coils are connected, the whole being connected to one large coil plate. On each of the single windings on this is coupled a large flat coil (called "field"). These flat coils are interwound in two groups; these groups represent the turns of a transformer. This couples, on one hand, on the flat coils of the other group (as secondary coils), and, on the other hand, on the anchor-plate coil which is placed between them. The third electrically independent circuit (called "directing circuit") regulates this transference. Figure 1 [not included in the BIOS Report] shows diagrammatically and in plan these interwound parts. Figure 2, the so-called basic diagram, shows the connections between these different parts. This basic diagram shows the conditions necessary for self-interruption. In consequence of this arrangement, different types of currents are created in different conductors (pulsed DC, AC, etc.).

The transformer coils, connected between the anchor plates, are connected in a peculiar way through thin-permanent magnet rods. Their main object seems to be to pre-magnetise the transformer cores. It is, however, very probable that they are also connected with the Barkhausen effect...

In his report, Coler also described the following simple, significant experiment:

Given, a solenoid consisting of two windings, one upon the other, of the same length and number of turns, enclosing a soft iron cylindrical core. Firmly attached to one end of the core is a pre-magnetised steel rod. If an alternating

current is passed through one of these coils, acting as primary, the residual magnetism of the steel rod is strengthened during one half-cycle through the magnetism induced in the core; during the other half it is weakened. If now the other winding is connected in series with the pre-magnetised steel rod (as secondary coil) in such a way that the secondary current must pass through the magnet, one half-cycle of the secondary current must be more or less subdued; in other words, a rectifying effect must be created.

It may be remembered that, according to measurement by Profs Kloss and Schumann, a high-frequency pulsed direct current (about 180 kc) is flowing in the output resistance of the apparatus, for the creation of which no other explanation is possible.

Another experiment with two double-wound solenoids, connected in series, revealed that "in such a secondary circuit a considerable DC component exists which can be strengthened by means which we shall not go into here...". Experiments were conducted with the plate and flat coil unit to test their interactions:

As the plates are not only charged as condensers but also have directed currents passing through them, it had to be assumed that their mutual influences not only consisted of a condenser effect but that they also created a magnetic field... It appeared that the *Ankertrakte* AC or BD are not all to be considered as oscillating units, but that the single group systems, consisting of plate to anchor coils to plate, already represent independent oscillation circuits. According to this, the apparatus contained ten such oscillation circuits... In order to make the apparatus work, the harmony of all oscillating circuits in their individual frequencies would evidently be necessary, at least within certain limits determined by the suppression in question...

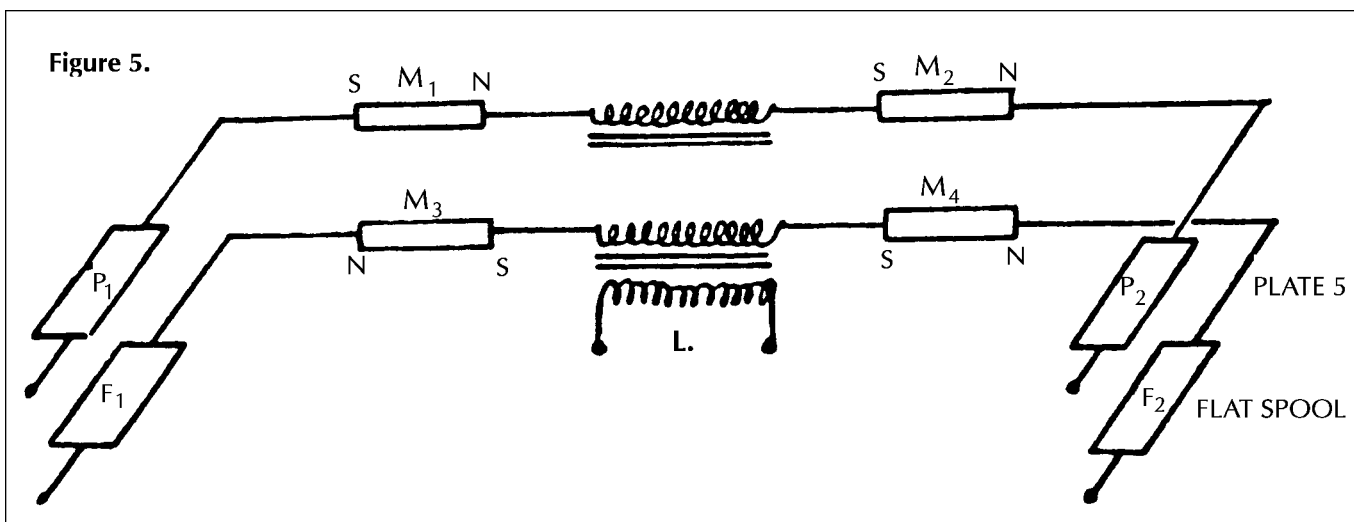

Figure 5.

The previous occasional success must be considered as due to chance.

The mutual influence of the flat coils upon one another could not, on the other hand, easily be examined because despite the great distance between the windings (25 mm) they have remarkably great apparent resistance (about 200 ohms at 10 kc).

It appeared that the power factor of both of the flat coils wound 1:1, in consequence of their peculiar interwinding has the astonishingly high value of 0.85. The value of the power factor was at a maximum at 10 kc, at which frequency the most favourable matching of the impedance... was obtained.

The repeated mention of 10 kc is also found in the scientific literature on the Barkhausen effect. After all his experiments and measurements, Coler offered the following explanation of the way in which the apparatus works:

Due to the connecting of the batteries, a current impulse is induced in the anchor circuit which charges the plates. The discharge circuit from the plates causes electrical interruption of short duration of the battery current in the field circuit, which furthermore inductively interrupts, or changes the direction of, the battery current in the directing current for a short time. The electromagnetic field induced by this process in the directing circuit by its dissipation, induces over the field circuit a current in the anchor circuit, recharging the plates, and so forth.

Due to the influence of the Barkhausen effect, each single process has an impulse-like character, and the necessary change of phase is produced to allow the regularity of the process.

Due to a source, up to the present not investigated and not explainable by existing scientific theories, an additional quantity of energy is freed during each cycle which leads to a continual raising of the amplitude of the mutual processes until the magnetic cores are saturated.

From the fact that in the resistance of the apparatus, pulsed direct current is flowing...[t]here is possibly an up-to-now unknown rectifying effect, or, alternatively, the gain in energy is produced only during one half of the cycle, either during the charging or discharging of the plates. The activity in the apparatus must take place *in the ten oscillation circuits in a phase-like manner...* No technical means were available to make the necessary tuning adjustments.

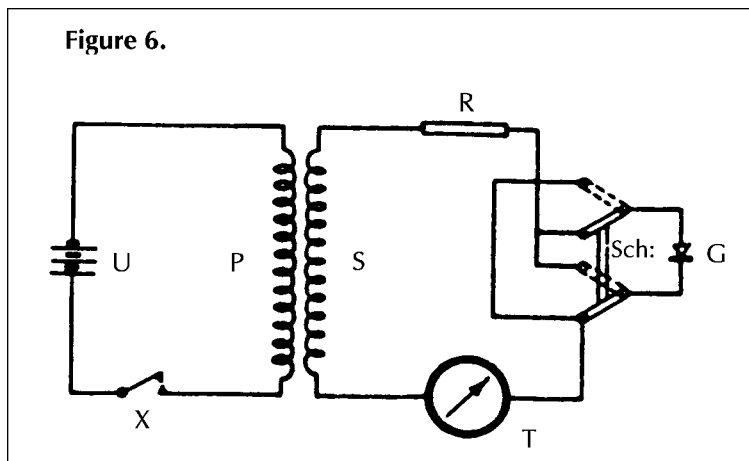

It is clear from the above that the success of the inventor up to now could only be due to chance, or happy accident. The necessity, therefore, arises to transfer the apparatus from the state of empirical development, with sufficient technical means and based on results of an exact basic research, to a state of working procedure which can be controlled.

Other experiments, conducted by Frohlich with the arrangement in figure 6, convinced Coler that his theory was correct:

The result obtained with this experimental arrangement...was the clear proof of a considerably larger energy during opening (intake), compared with closing impulses... The [10–50%] difference is always in favour of the opening impulse... Consequently, this observation can also be considered as a proof of the fact that an energy difference exists... [There is a] considerable, but extremely short, energy peak of the opening impulse... My development of the Space Energy Receiver was based on this and was successful.

In the 1980s, George Hathaway of PACE (Planetary Association for Clean Energy) constructed a *Magnetstromapparat* which produced 50 millivolts and he demonstrated it at unconventional technology conferences. There has been no news of further development.

The Barkhausen effect, upon which the Coler inventions work, is a low-field phenomenon that occurs when a ferromagnetic material is subjected to a change in the applied magnetic field. A series of discontinuous steps develop, corresponding to reversals in magnetisation domain volumes from 10^{-10} to 10^{-8} cm³. The size of the discontinuities can be increased by stressing the magnet. Possibly the soft iron magnets which Coler used were subjected to such stress by ultrasonic magnetostriction from the coil windings at the 180 kHz resonant frequency.

One can only wonder why British Intelligence declassified the Coler report, but we can be glad they did. If only they had seen fit to include more schematics of the *Stromzeuger*, because the available diagrams are woefully inadequate. At least we now know a few key facts:

- 1) Ferromagnetism resonates at 180 kilohertz.
- 2) The Barkhausen effect can be amplified to provide useful power (10 kHz is another key frequency here).
- 3) "...some of the magnets are wound in a clockwise direction looking at the N-pole (called 'left') and others in an anti-clockwise direction (called 'right')." The resistance of the magnet-coil combination was about 0.33 ohm.

4) "The basic principle is that an electron is to be regarded not only as a negatively charged particle but also as a South magnetic pole."

5) "The novel feature is that the capacities are connected to the secondary core *through permanent magnets...*"

6) "There is a considerable, but extremely short, energy peak of the opening impulse."

It is to be hoped that the *Stromzeuger* can be redeveloped, since it is a relatively simple, low-technology device requiring no exotic components. It should not be left "to chance, or happy accident", as it was for Hans Coler.

Note:

The BIOS Report No. 1043 is available from Rex Research (PO Box 19250, Jean NV 89019, USA) at a cost of US\$9.00 postpaid, or US\$11.00 overseas.

ZERO-POINT ENERGY Update on the 'Joe Phenomenon'

by Ian of NuTech 2000 © 1998

Since NEXUS published the extract from the Barry Hilton/NuTech book, *The Joe Phenomenon: How to Run Your Car on Zero Point Energy* [Science News, 5/05], our office has become very busy receiving calls from all around the world including Ireland, the UK, New Zealand, Canada and the USA.

Interest in the so-called 'Joe Phenomenon' has been marvellous, and as many experimenters delve into its mysteries the technology will become better-understood and easier to replicate.

I'm very happy that a team of physicists from the other side of the planet called me, expressing their desire to replicate and fully investigate this Joe Phenomenon. I am hopeful this may result in giving this new energy source the credibility that it deserves, in conjunction with a scientific analysis as to what exactly is running the car and all its associated chemistry and physics—be it orthodox or non-orthodox science. Indeed, Joe has unlocked an awesome energy source that is so simple and yet so profound.

To this date, only a few experimenters have duplicated the Joe Phenomenon, but, as time passes, the jigsaw pieces are slowly coming together. However, I know many folk may have difficulties and frustrations as they pursue what I have dubbed 'the Holy Grail'—that is, the manifestation of 'free' energy.

As many NEXUS readers are aware, the desire to seek, find and have demonstrated to one's satisfaction a real and working 'free energy device' can be a lifetime quest. For me, it started in the 1970s. However, it seems that the day-to-day commercial reality of free energy is still a good way off. But the day is coming.

In the meantime, for those of us who have some tinkering time and a little money, the Joe Phenomenon is certainly the ideal project.

For those who have purchased the Joe Phenomenon book and associated video, *Out of the Horse's Mouth*, I would like to offer some helpful hints that have been passed on to me by the book's author, Mr Barry Hilton.

The first thing to say is that this cell is not easy to replicate, but on the other hand some folk may get the cell fired up without any trouble at all. It will depend entirely upon each experimenter and how they approach it. So often we garnish a set of plans with our own ideas and think, "I can build it better this way...or that way". I simply warn folk not to deviate from the plans as revealed by Joe.

Some changes may seem insignificant, but Joe talks a lot about the 'fields' in his cell, which he has identified through careful observation (these fields are not explained in orthodox textbooks). Joe cautions that it is very important not to corrupt these fields.

Once a cell has been replicated, you can make changes, observe the effects and possibly come up with a new variation in the design that does work. In the meantime, a lot of frustration may be avoided if the current plans are adhered to as described by

Joe—otherwise I fear we may end up with an exotic new variety of doorstop!

The second important point is not to rush into making the car cell, as you will not be able to observe what is going on inside it. The video, *Out of the Horse's Mouth*, shows Joe demonstrating his glass cell which has the concentric tubes set up in a big glass jar with an open top. If you have trouble getting a glass jar, I suggest you try a Myer department store [in Australia]. They have a hinged-lid jar, but a glazier will need to cut the top portion off the jar and drill the appropriate-sized hole in the bottom for the negative electrode bolt to go through. Using the rubber stoppers (e.g., from Clark Rubber), the cell tubes can be locked into this jar as though it were a metal cell container but with an open top. (Do not pressurise a glass cell.)

When the cell is properly set up and aligned, you will notice the gas bubbles descending between the outside tube and the glass jar. The bubbles then whip around the bottom of the outer tube and back up through the inner tubes.

Of course, you can only see this effect when set up in a glass cell, but it is vital to get this far before even thinking about a car cell. However, the crucial thing is to condition the cell tubes and charge the water. When these two things are achieved, you are getting into business.

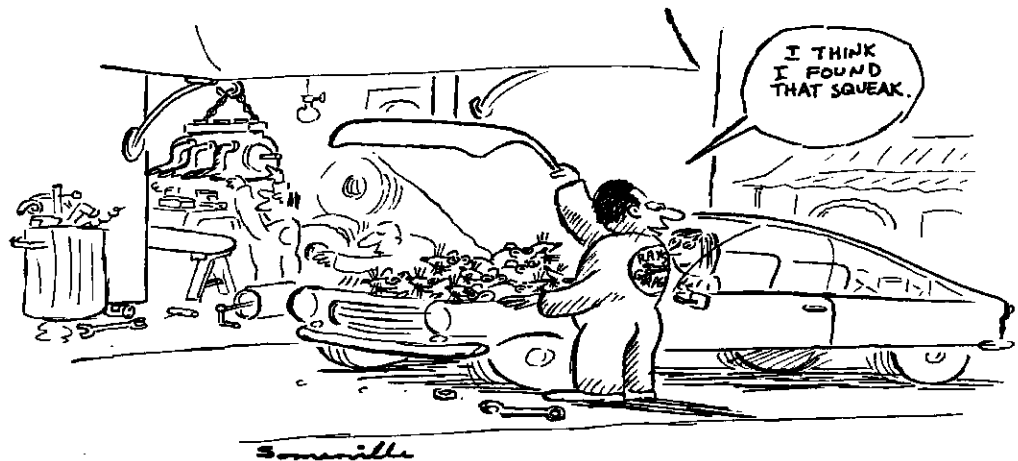

NEWSCIENCE NEWSCIENCE NEWSCIENCE

At this stage, a few comments may be of assistance about the type of water to use. I would recommend a read of Callum Coats' book, *Living Energies* (available from NEXUS), which is a great revelation about the nature of water and its ability to memorise and energise. Callum explains that the best-energised water comes from high mountain springs at 4°C. The blue waters of New Zealand's fast-flowing rivers may also be an excellent choice to begin with (if you live in New Zealand). These waters will already be highly energised and rich in minerals, giving a good current flow up to 5 amps. Another suggestion is to use one of the many water energisers now on the market prior to putting the water in the cell.

Joe says he used his local creek water and even town water. We have no idea about the make-up of his water, but it would seem that once the plates of the cell are conditioned it is easier to condition ordinary water.

Joe's 'keg' cell is used to purify and condition a quantity of water for the car cell, but I would suggest using the glass cell as the purifying and pre-conditioning cell. As the sludge forms on the surface, simply overflow the cell so the sludge runs off the surface to a catchment tray. Likewise, for settlement, pour off the clean water, wash out the cell and refill the cell with the same water or fresh water if necessary. This may have to be done many times while conditioning the cell. Do not allow the cell to

become hot, as this will also deplete the energy. The optimum level of energy is absorbed at 4°C.

Unfortunately you will find that the stainless steel milk separator cones are quite scarce if you wish to build the keg cell, but auctions in country dairying areas are a good source.

Once the plates are conditioned, they can then be incorporated into the car cell and a new set of tubes then set up for a pre-conditioning cell for future use. Your car cell will need topping up from time to time or re-charging in the event of a discharge, so it is necessary to have a bench cell handy.

Whatever you do, *don't use electrolytes* or you will kill the energy of the cell.

As the cell becomes aligned, you will notice that the explosions from the bubbles become more acute. The surface tension will also increase, which allows big bubbles to form. When you light these bubbles, your eardrums should literally ring. Joe says that a light bulb above the cell could even burst from the explosion. If this happens, your cell is ready to be installed in the car.

Readers may be interested to know that when Barry Hilton was experimenting with his keg cell, he found that the water did not pass through a large domestic strainer when he was skimming off the scum from the top of the water. The strainer had a good half-inch of water in it, and the water refused to pass through the mesh until the

underside of the mesh had been dipped in water as well.

It's also been reported to me that luminescence or flashes of light have been seen in the keg cell as the water became highly charged.

Note that it is advisable to set up your cells well away from intense electrical fields as may be found in a workshop. However, there have been reports that when the cells have been set up and used outside, they seemed to exhibit some weather-modification effects. NEXUS readers may be aware of Trevor James Constable and his orgone weather-engineering research. I welcome further feedback from outdoor experimenters.

One last point. When selecting your stainless steel, don't forget to take along a small neodymium magnet to test that the steel has the least magnetic properties. The less magnetism in the cell, the better the chance of making it work. Machine your tubes with precision and use a stainless steel cleaning agent to bring them up nice and shiny.

Do not allow electroplating of the plates to occur due to high voltages, as this will inhibit the functioning of the cell. Twelve or 24 volts should do the job, but Joe does use a Telecom charger which is around 60 volts. You may like to try the electropolishing process as this will give a brilliant finish to the tubes which may assist the field alignment in the cell, as in a magnetron. However, this is our suggestion, not Joe's.

I want to thank NEXUS readers on behalf of Joe and the author, Barry Hilton, for the great enthusiasm and interest shown in this most amazing phenomenon. The Earth is going through extraordinary changes at present, and if we are to have any future in the next millennium it is vital to bring this technology to the fore.

Editor's Note:

For further details, contact Ian of NuTech 2000, PO Box 255, Ivanhoe, Victoria 3079, Australia; telephone/fax +61 (0)3 9457 2814; e-mail <nutech@arc.net.au>. NuTech 2000 can supply copies of Barry Hilton's 40-page book, *The Joe Phenomenon: How to Run Your Car on Zero Point Energy* (AUD\$39.00 inc. p&h in Australia; USD\$41.00 foreign p&h) and the video, *Out of the Horse's Mouth* (AUD\$25.00; USD\$30.00; PAL and NTSC).



NEWSCIENCE NEWSCIENCE NEWSCIENCE

US PATENT #5,590,031: SYSTEM FOR CONVERTING ELECTROMAGNETIC RADIATION ENERGY TO ELECTRICAL ENERGY

INVENTORS: Mead, Jr, Franklin B.; Lancaster, CA 93535
Nachamkin, Jack; Poway, CA 92064

ASSIGNEES: None

ISSUED: December 31, 1996 **FILED:** July 27, 1994

SERIAL NUMBER: 281271 **MAINT. STATUS:**

INTL CLASS (Ed. 6): H02M 001/00

US CLASS: 363/008; 363/178; 342/006

FIELD OF SEARCH: 363-8, 13, 178; 342-6, 61, 73, 173, 175

ABSTRACT: A system is disclosed for converting high frequency zero-point electromagnetic radiation energy to electrical energy. The system includes a pair of dielectric structures which are positioned proximal to each other and which receive incident zero-point electromagnetic radiation. The volumetric sizes of the structures are selected so that they resonate at a frequency of the incident radiation. The volumetric sizes of the structures are also slightly different so that the secondary radiation emitted therefrom at resonance interferes with each other, producing a beat frequency radiation which is at a much lower frequency than that of the incident radiation and which is amenable to conversion to electrical energy. An antenna receives the beat frequency radiation. The beat frequency radiation from the antenna is transmitted to a converter via a conductor or waveguide and converted to electrical energy having a desired voltage and waveform.

US REFERENCES: (No patents reference this one)

<u>Patent No.</u>	<u>Inventor</u>	<u>Issued</u>	<u>Title</u>
3,882,503	Gamara	5/1975	Wave detection apparatus
4,725,847	Poirier	2/1988	Reflector antenna having side-lobe nulling assembly with metallic gratings
5,008,677	Trigon et al.	4/1991	Anti-jamming device for a radar provided with a reflector antenna

EXEMPLARY CLAIM(S): (Show all 14 claims)

What is claimed is:

1. A system for converting incident electromagnetic radiation energy to electrical energy, comprising:
 - a first means for receiving incident primary electromagnetic radiation; said means for receiving producing emitted secondary electromagnetic radiation at a first frequency; said first means for receiving, having a first volumetric size selected to resonate at a frequency within the frequency spectrum of the incident primary electromagnetic radiation in order to produce the secondary electromagnetic radiation at the first frequency at an enhanced energy density;
 - a second means for receiving the incident primary electromagnetic radiation; said means for receiving/producing emitted secondary electromagnetic radiation at a second frequency, the secondary radiation at the first frequency and the secondary radiation at the second frequency interfering to produce secondary radiation at a lower frequency than that of the incident primary radiation; said second means for receiving, having a second volumetric size selected to resonate at a frequency within the frequency spectrum of the incident primary electromagnetic radiation in order to produce the emitted secondary electromagnetic radiation at the second frequency at an enhanced energy density;
 - an antenna for receiving the emitted secondary electromagnetic radiation at the lower frequency, said antenna providing an electrical output responsive to the secondary electromagnetic radiation received;
 - a converter electrically connected to said antenna for receiving electrical current output from said antenna and converting the electrical current output to electrical current having a desired voltage and waveform.

RELATED US APPLICATIONS: None

FOREIGN APPLICATION PRIORITY DATA: None

FOREIGN REFERENCES: None

OTHER REFERENCES: None

ATTORNEY, AGENT OR FIRM: Papageorge, Chris

PRIMARY/ASSISTANT EXAMINERS: Wong, Peter S.; Berhane, Adolf

(Source: Internet website, www.patents.ibm.com/details?patent_number=5590031)

— The New Swirled Order — UK CROP CIRCLES OF 1998

It's been another exhilarating season for crop circles in England, but these awe-inspiring formations still defy explanation.

A compilation of reports
by **Marcus Allen** © 1998
NEXUS Magazine, UK
and
by **Colin Andrews** © 1998
CPR International, USA

Crop circle enthusiast Marcus Allen, of NEXUS Magazine's UK Office, has filed the following report on the 1998 crop circle season. — Ed.

Do you believe that all crop circles are man-made? Do you believe that no crop circles are man-made? Most people who are asked these questions invariably answer "No" to both—which can only mean that a phenomenon exists. In 1998, crop circles have continued to appear as prolifically as in past years, intriguing the thousands of visitors to southern England where the majority of formations occur.

Reports and photographs of crop circles from Belgium, Canada, Croatia, the Czech Republic, Finland, Germany, Holland, Israel and the USA have been received and are regularly updated on the Crop Circle Connector website, <www.cropcircleconnector.com>. They indicate just how widespread the phenomenon has become.

The first major formation in England in 1998 appeared between 12 midnight and 2 am on Monday 4 May. The Beltane Wheel measured over 180 feet across, consisted of 33 segments, and lay in a field of oilseed rape—a brittle and easily damaged plant about four feet high. The timing of its appearance is known because a local photographer had set up his cameras to photograph the Moon and the following sunrise overlooking this field. He would have been aware of other people nearby, but no one else was there.

Lying within sight of Silbury Hill and easily visible from the busy A4 (London to Bristol road) the formation immediately attracted press and TV interest. However, the sceptical camera crew were unable to explain why their usually reliable equipment became progressively non-functional inside the circle.

The geometry of the Beltane Wheel also received attention, as 33 divisions of a circle is not an obvious number to lay out. Each segment appeared to be part of three interlocking circles. The design is hard enough to create on paper, let alone on a sloping field in darkness. The formation is baffling.

The English summer is usually notable for two things: little sunshine and few hours of darkness; six at most. As in previous years, new formations were now appearing nearly every night, with as many as two and three each night during July and August. More than 150 crop circles in England in four months this year—much the same as in each of the previous 10 years—cannot be dismissed as the nocturnal antics of a few pranksters, despite the dour insistence of some trying to explain away this most visible phenomenon.

This very visual aspect has attracted the attention of TV networks this year. NBC, filming in New Zealand, and the BBC and ITV in Britain have all commissioned the same few people to perform for their cameras—the results being loudly proclaimed as the explanation we've all been waiting for. Compared to the full range of crop circles, and with now over 3,000 documented worldwide, their efforts appeared laboured, stunted and lacking in creativity. They took many hours to complete their designs, and even needed the help of floodlights in some cases.

Whatever explanations are considered for how crop circles are formed, and there are many, it seems they may not be so relevant, for it is the effect these extraordinary shapes have on people which is the true measure of their significance. Lives really have been changed, and new and more productive life-paths seem to have arisen from involvement with crop circle research.

This became increasingly evident at the two major crop circle events this summer. The Crop Circle Celebration weekend, organised by Francine Blake and the Wiltshire Studies

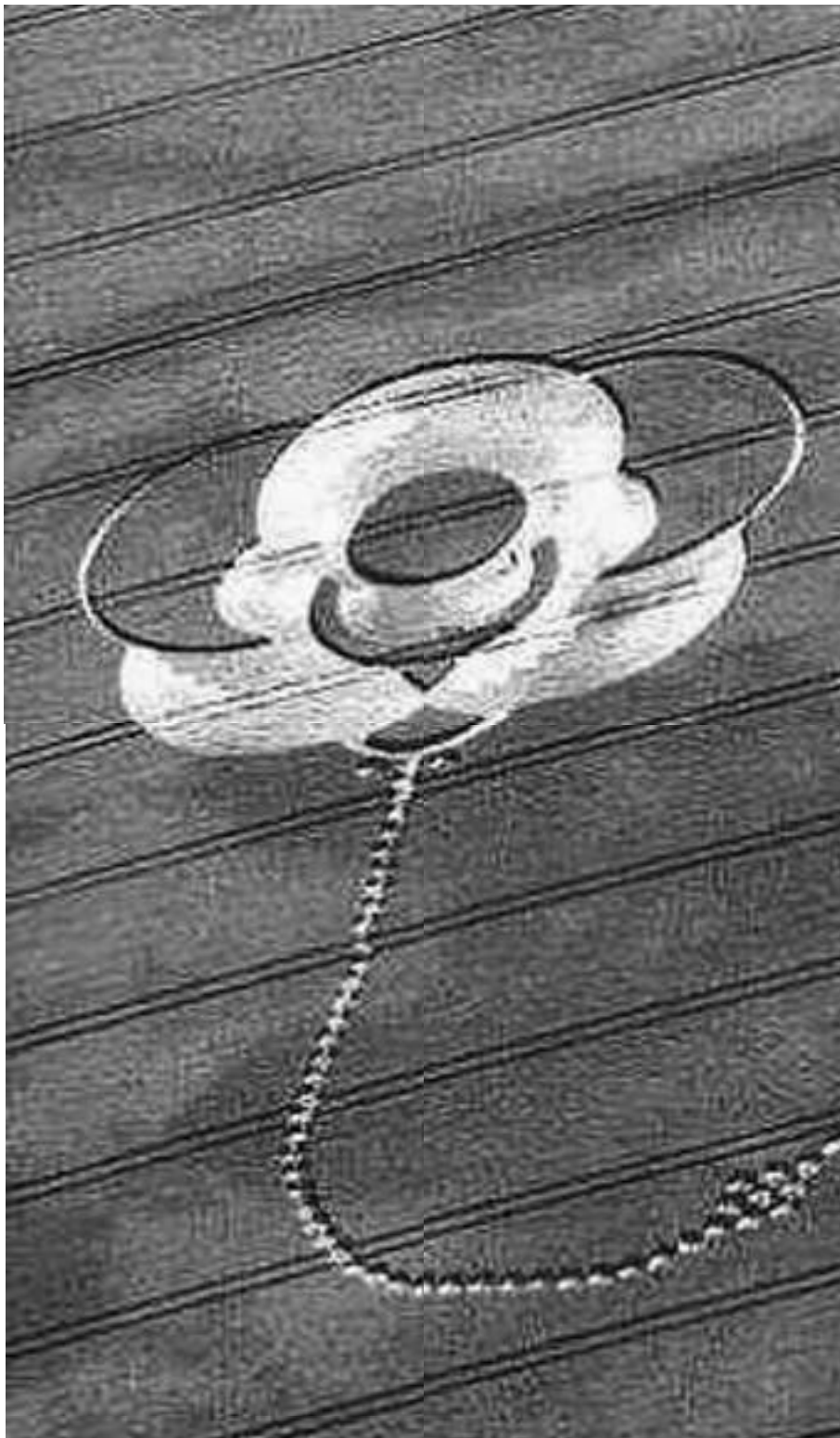

Beckhampton, near Avebury, Wiltshire. Reported 21 July. The body is 200 feet wide, and the tail, consisting of 52 circles, is over 300 feet if straightened. Photograph © 1998 Lucy Pringle.

Group, was held at Alton Barnes, Wiltshire, on 18–19 July. Attracting more people than ever, two large marquees for food and stalls were needed in addition to the famous Coronation Hall. An international group of 14 speakers presented a wide range of subjects—linked, as always, to the impact crop circles have had on their research.

Andy Thomas's informative and entertaining overview of details noted in crop circles and his unique slide show of formations recorded during the past 10 years were useful, as always, in reminding people just how extensive this phenomenon actually is and how little we really know about it yet. Andy's new book, *Vital Signs* (see review this issue), was also launched at this weekend. Its subtitle accurately sums up its purpose: "A Complete Guide to the Crop Circle Mystery and why it is NOT a Hoax".

Michael Glickman, over from California, showed in his own inimitable style the increasingly sophisticated geometry identifiable in crop circles.

Dr Chet Snow linked the Hopi and Maya prophecies and his own Earth changes predictions with the symbolism of the English crop circles.

Kurt Browne presented material on African spiritual tradition and the Kabbalah, showing how humanity's search for wisdom and truth can only benefit from contact with such apparently diverse sources.

A few days before the celebration weekend in 1997, as if in some sort of acknowledgement the circle-makers produced one of last year's highlights: the 12 Torus rings. For 1998 they did not disappoint.

In East Field on 9 July, for the first time ever there appeared a seven-sided formation, 300 feet across and surrounded by nearly 100 smaller circles. The huge, flattened area was laid down in a flowing pattern, only fully appreciable from the air.

In another first this year, many visitors were able to take advantage of a local helicopter service to view the area's formations. It was in this formation that Rod Bearcloud Berry, from the Native American Osage tribe, held the dramatic closing ceremony of the weekend which, for many, highlighted the ongoing spiritual connection felt by people drawn to experience the mysteries surrounding crop circles.

The following weekend, 24–26 July, saw the 9th Glastonbury Symposium: "Investigating Crop Circles and Signs of Our Times", held in the recently refurbished Assembly Rooms. Roland and Clare Pargeter organised what many attendees agreed was the best symposium so far. Starting on the Friday with an 80-person

coach tour of the formations and a full day's lectures for the many left behind, this event attracted attendees from across America and Europe, with some from South Africa and Australia. Those of us living in England really only appreciate how fortunate we are when we meet enthusiasts who have travelled so far to visit the crop circles.

With over 20 speakers scheduled over the three days, the program was kept on course by Roland's gentle authority. Brian O'Leary—and his Lapis Pig (you had to be there!)—gave an ex-astronaut's view of just how far some researchers are challenging existing paradigms. David Kingston showed remarkable video footage of a UFO over Dorset, England. Peter Paget warned of the dangers ahead if we do not become more aware of the potential chaos from the so-called Millennium Bug. Lynn Picknett and Clive Prince revealed their groundbreaking research into St John the Baptist whose influence has been suppressed for so long but is now being reassessed.

With many speakers of course talking about crop circles, and with the blending of various apparently unconnected subjects—all concentrated within the unique atmosphere of Glastonbury—this symposium ended with the realisation for many that the jigsaw is taking shape, pieces are fitting together and a bigger picture is emerging. Crop circles are the catalysts.

As if emboldened by the attention, the circle-makers (whatever their origin) completed the season with a sustained high level of spectacular formations through to the end of August. Some of these were cut down by combine harvesters within hours of their appearance, but not before photos could be taken—now the only evidence that these formations ever existed.

There may never be a definitive answer to the often asked question, "What do they mean?" If you have to ask the question, you would probably not appreciate the answer because it would be someone else's answer. Perhaps there is not meant to be an answer, because crop circles may not mean anything except what each person wants them to mean.

To find out that there truly is 'magic in the fields', do try to visit at least one crop circle before you depart Planet Earth.

Note: Marcus Allen can be contacted at the NEXUS UK Office, 55 Queens Road, East Grinstead, West Sussex RH19 1BG, tel +44 (0)1342 322854, fax +44 (0)1342 324574.

The following report, dated 11 July 1998, is from well-known crop circle researcher Colin Andrews, and was downloaded from the Crop Circle Connector website <www.cropcircleconnector.com>.

It has been many years since I've heard so many UFO reports while researching the ever mysterious crop circles. These past 48 hours have been exceptional for the sheer quantity and strangeness of the reports.

On Thursday 9 July, at around 7 am, the first report was received from Alton Barnes, Wiltshire, of an enormous new crop circle design in a field which has seen many—East Field, below the ancient burial tumulus called Adam's Grave. The design was a Koch fractal snowflake pattern, like two others seen nearby dur-

ing 1997. This one had over 140 small circles surrounding the snowflake outline and was around 300 feet across [see photograph below].

At approx. 11 pm on the same night of discovery, numerous army helicopters were witnessed sweeping the area, as if they were searching for something. Oddly, though, some had their light beacons turned off while another was flying with a very powerful searchlight scanning the ground. Then suddenly, many witnesses (I have spoken to three of them) saw an illuminated sphere being chased by one of the army helicopters. The helicopter scanned its searchlight onto some of the researchers, as this chase took place across fields from Adam's Grave to the far side of East Field. This is the same field that many viewers of *Strange Universe* and *Sightings* TV programs would have seen in the film of two British Army helicopters hovering over a small glistening ball three years ago.

Around two hours before this apparent UFO chase took place, farmer Terry Butcher was out on his farm to the south, also in Wiltshire, when he witnessed a large tube open up the clouds. He described the clouds opening from high level to the lowest clouds in a straight line with two straight edges. He said it was like a long tube, inside which there was no cloud. Within just moments, the clouds filled back in and everything returned to normal.

Last night (10–11 July), literally thousands of telephone calls were received from Scotland and down the Welsh coast to Cornwall, south-west England. People reported to police stations and coastguards that they had seen numerous lights form

into a shape like a "Z" or a "2". Many said the lights had smoke coming from them, like flares. The coastguards began to investigate, thinking perhaps the witnesses had seen meteorites.

This morning (11 July), statements were issued on many British television and radio stations from the Ministry of Defence who explained the sightings as meteorites breaking up. A coastguard spokesman said the events remained a mystery, and commented jokingly, "The truth is out there".

A new major crop formation appeared on the night of 9–10 July at West Woods, north of Alton Barnes. Numerous people (some of whom I have also interviewed) said they witnessed flashes of light coming from the area concerned. The British Met Office said there was no lightning in southern England at that time.

Note: Colin Andrews can be contacted at CPR International, PO Box 3378, Branford CT 06405-1978, USA.

To obtain more details on the photographs presented in these pages, send SAE to photographers:

Steve Alexander, 27 St Francis Road, Gosport, Hants PO12 2UG, UK; tel +44 (0)1705 352867.

Lucy Pringle, 5 Town Lane, Sheet, Petersfield, Hants GU32 2AF, UK; tel/fax +44 (0)1730 263454.

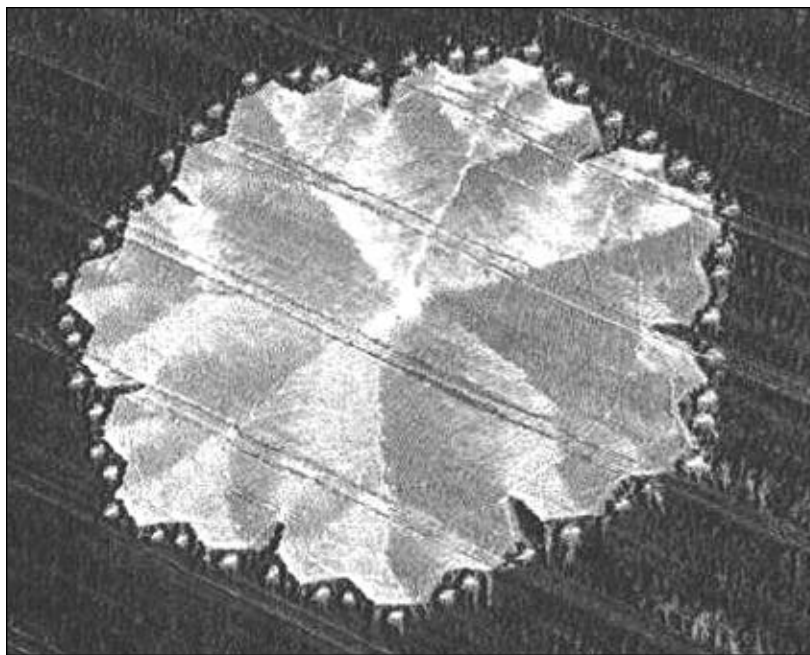

East Field, Alton Barnes, Wiltshire. Formed 9 July. Sevenfold Snowflake: a 295-foot formation surrounded by 147 little circles. Photograph © 1998 Steve Alexander.

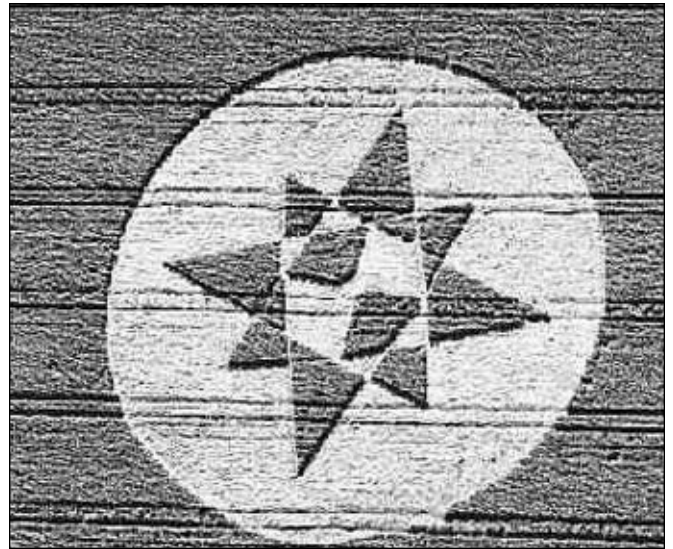
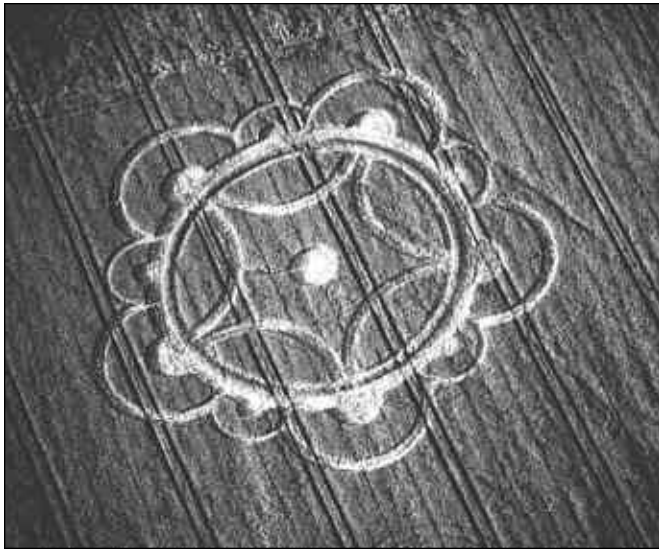

Top left: Fareham, near Portsmouth, Hampshire. Reported 11 July. Photograph © 1998 Steve Alexander.

Top right: Avebury, near Marlborough, Wiltshire. Reported 24 August. Photograph © 1998 Lucy Pringle.

Below: Silbury Hill, near Avebury, Wiltshire. Reported 23 July. A four-armed Julia Set, over 200 feet across, in wheat. Photograph © 1998 Lucy Pringle.

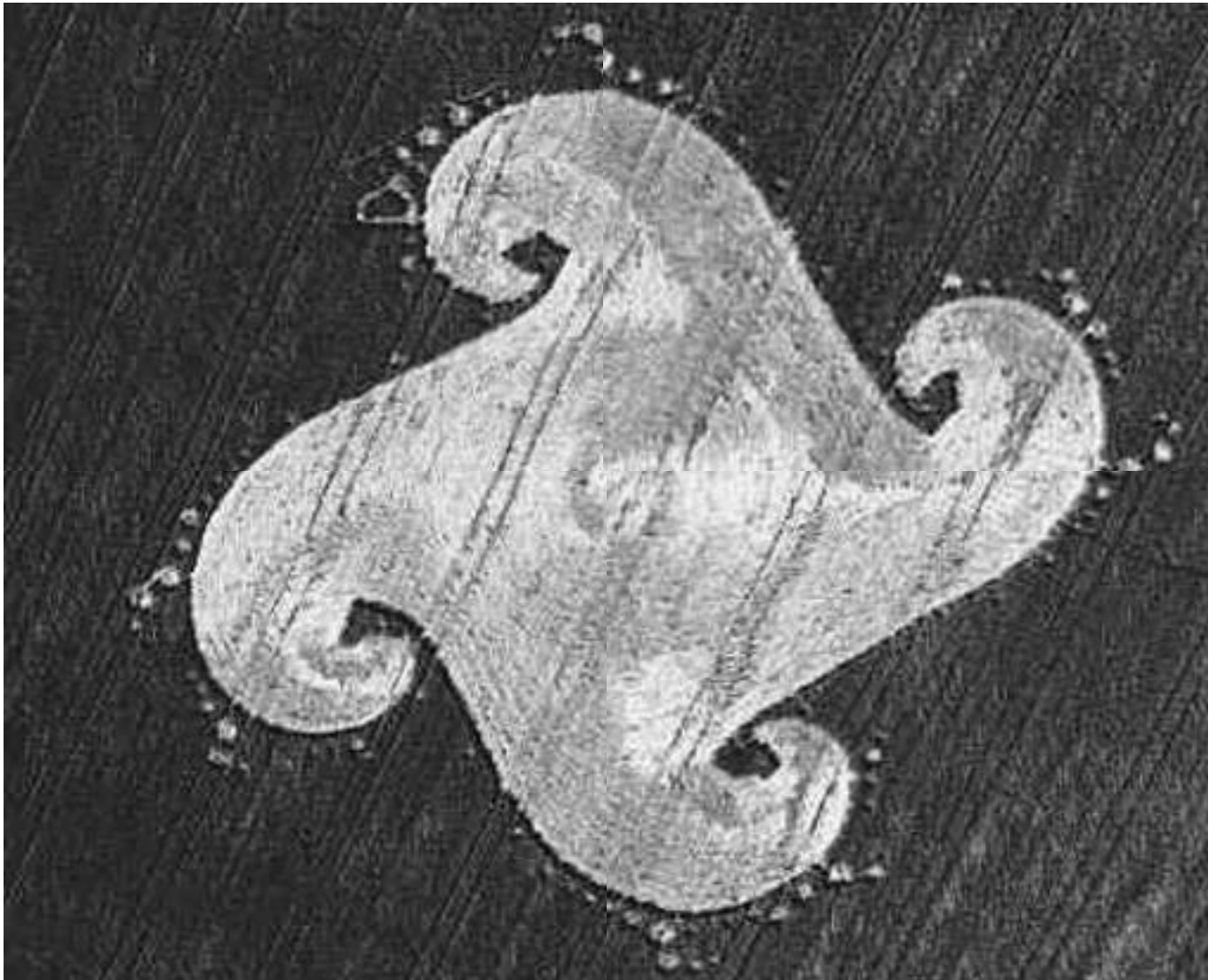

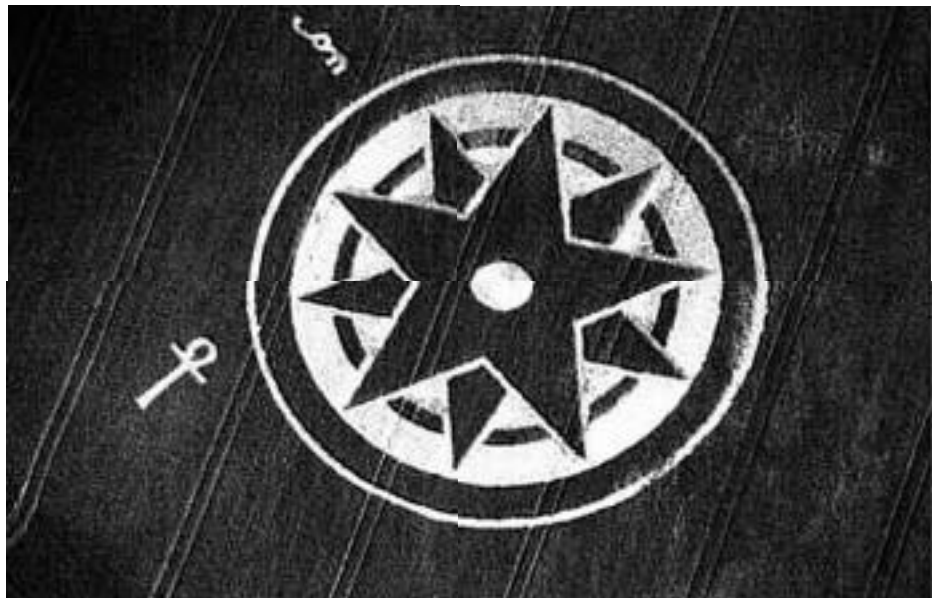
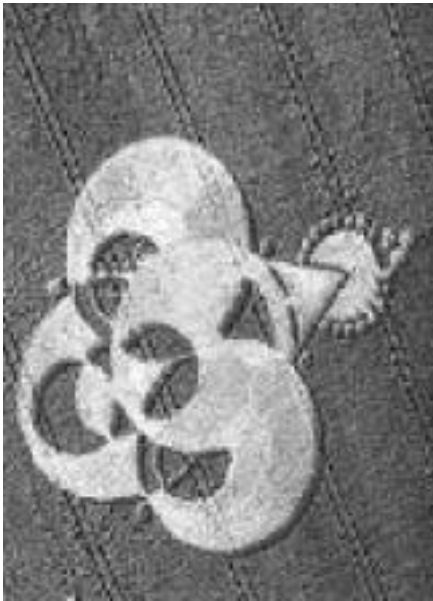

Top left: Lockeridge, near Avebury, Wiltshire. A 400-foot formation in wheat. Reported 6 August. Photograph © 1998 Lucy Pringle.

Top right: Dadford, near Silverstone, Buckinghamshire. A 190-foot-diameter design in wheat. Reported 4 July. Photograph © 1998 Steve Alexander.

Middle right: Hackpen Hill, near Broad Hinton, Wiltshire. Reported 17 August. This formation is about 150 feet from corner to corner. Photograph © 1998 Steve Alexander.

Bottom left: Lockeridge, near West Overton, Wiltshire. A 200-foot-long formation in barley. Reported 25 May 1998. Photograph © 1998 Lucy Pringle.

Bottom right: West Woods, Lockeridge, near Avebury, Wiltshire. Reported 10 July. Photograph © 1998 Steve Alexander.

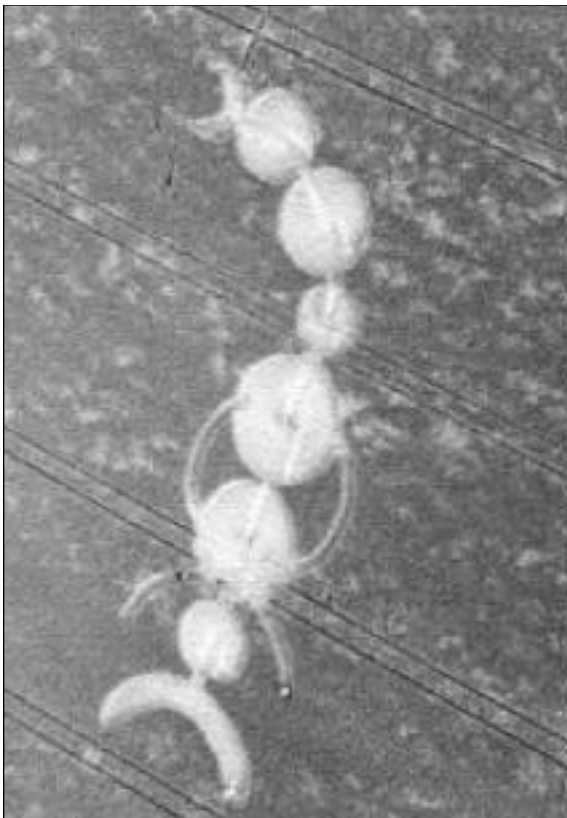
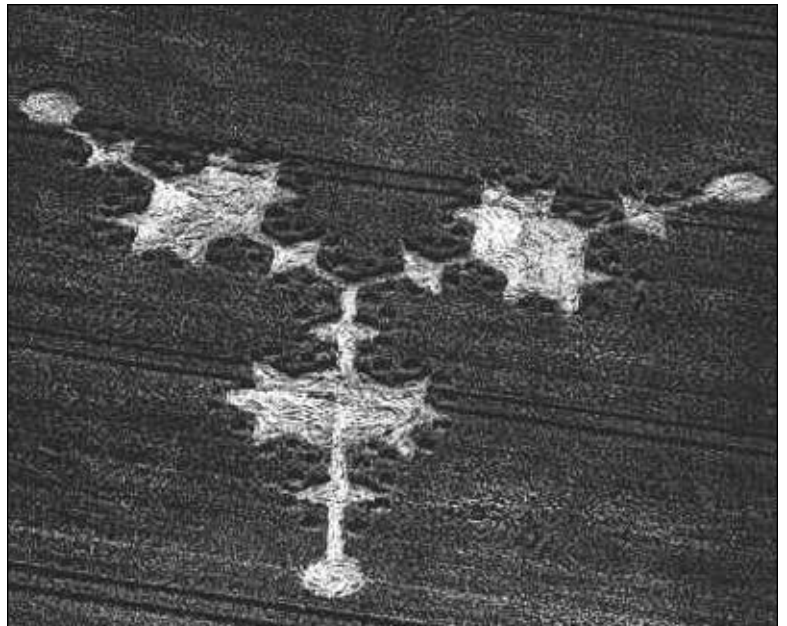

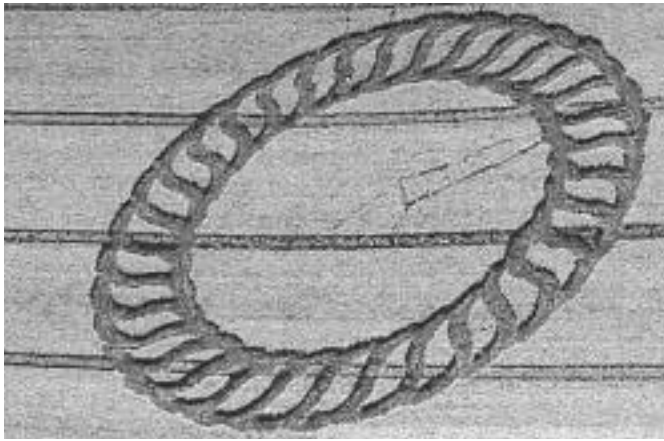

Top left: West Kennett Longbarrow, Near Avebury, Wiltshire. Reported Monday 4 May. Diameter 140 feet. Photograph © 1998 Lucy Pringle.

Centre left (top): A 200-foot formation in wheat, reported 8 August. Photograph © 1998 Steve Alexander.

Centre left (bottom): This 300-foot formation appeared 19 August near Avebury "Sanctuary", Wiltshire. Photograph © 1998 Steve Alexander.

Bottom left: A 160-foot formation arrived near Danebury Ring Hill fort, reported 2 August. Photograph © 1998 Steve Alexander.

Below: Photograph © 1998 Lucy Pringle. This 300-foot wheat formation arrived next to Tawsmead Copse in West Stowell, Wiltshire, on 9 August.

Middle right: Yatesbury, near Avebury, Wiltshire. Reported 10 August. Photograph © 1998 Steve Alexander.

Bottom right: Windmill Hill, near Petersfield, Hampshire. Reported 10 July. Photograph © 1998 Lucy Pringle.

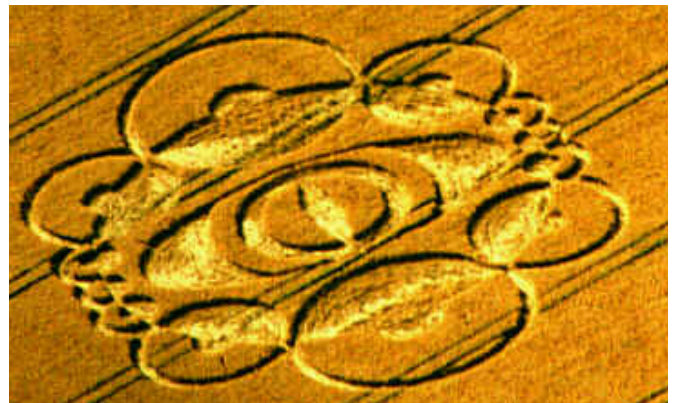
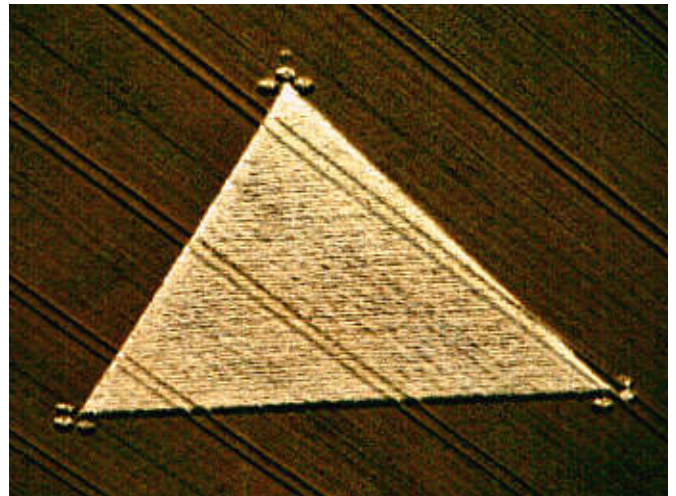
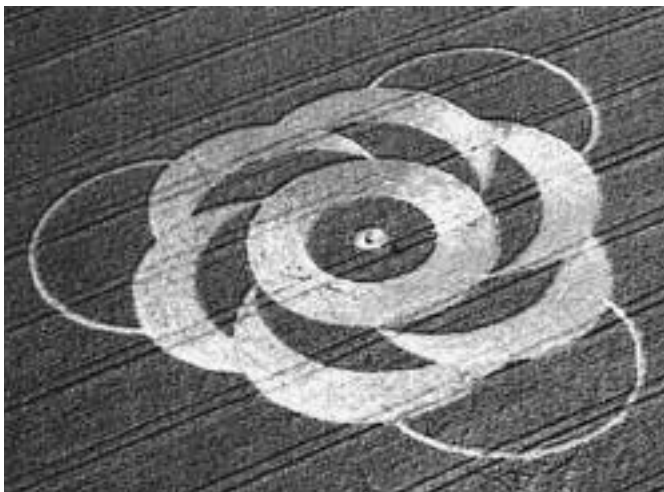
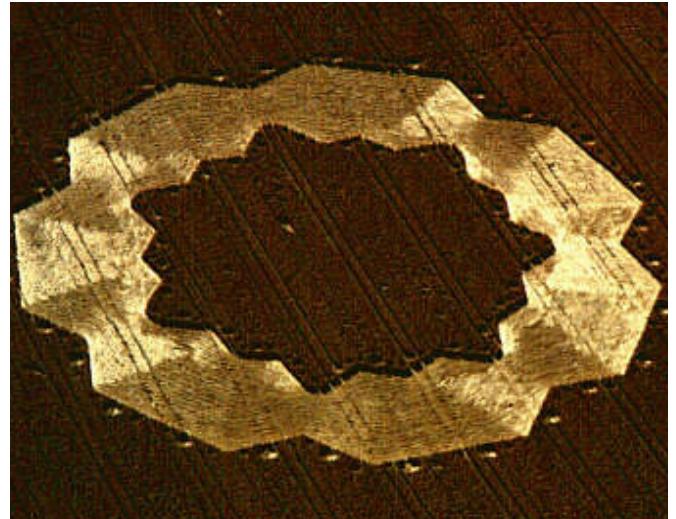
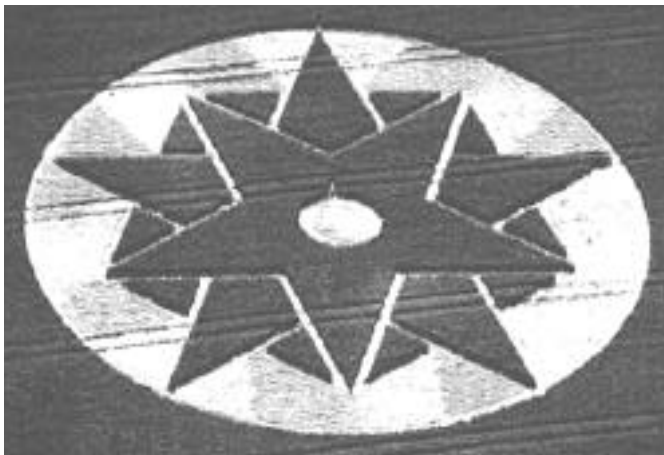



SUPER TELESCOPE CAMERA FILMED UFO AT 4,000+ MPH!

In 1963, US Air Force scientist Dr Walter F. Manning invented a telescope capable of observing a missile in flight at 130 miles down range. It had a near-1,000-inch effective lens which, coupled to a high-speed camera, was capable of filming the closest details of a missile, even one moving at thousands of miles per hour.

The 1,000-inch super telescope, utilising diffraction grating technology, was first deployed at Big Sur in 1964. Manning, together with Dr Robert M. Jacobs, used it that year to film the very first test flights of a nuclear anti-missile missile.

However, after developing the film of the test flight, the two scientists discovered they had captured more than just one of the Air Force's latest 1,000 mph super missiles.

The Air Force's Office of Special Investigations (OSI) called Jacobs into a special meeting to review an image taken of a disc-shaped craft overrunning the 1,000-miles-per-hour nuclear anti-missile missile, engaging in what may have been high-speed photo shots of its warhead and propulsion system in flight, circling the craft at extreme speed as if examining it from every angle.

According to calculations the UFO, estimated at about 60 feet in diameter, had to have been operating in excess of 4,000

mph alongside the anti-missile and at hundreds of miles per hour latitudinally. The disc-shaped UFO was not only able to fly precisely around the missile but it easily outpaced it, even though the missile was travelling at full speed.

The film footage taken through the telescope apparently shows the disc rapidly circumnavigating the anti-missile missile while the missile was tracking at several thousand miles per hour. By implication, anti-missile missile technology, coupled with nuclear warhead technology, could represent a threat even to an advanced extraterrestrial species.

Dr Jacobs has commented publicly about the device: "Now, exactly *what was that?*"

His obvious anger over the official secrecy surrounding UFOs is both credible and authentic. He is also a student of diplomacy, and knows that failure to respond to the UFO's 'symbolic concern' about our nuclear anti-missile missile capability with some kind of genuine 'gesture' could represent a 'primitive

threat' to the UFOs, from wherever they have originated.

Dr Jacobs was sworn to secrecy after being questioned about the Air Force's film of the UFO. He was told, "This never happened!", and advised of the repercussions of revealing the event—which, 34 years ago, would have involved his incarceration for the better part of his life.

Later, when Jacobs was long retired, he became disenchanted with the Air Force's official policy on the UFO event, and, possessing a conscience that would not allow him to continue his secrecy about so impor-



THE TWILIGHT ZONE

tant an event, he went public about the entire affair. He has indicated that he no longer cares what discipline or ruination the Air Force might dish out in his now later years.

The Air Force, however, responded to enquiries by issuing false reports about Dr Jacobs. It claimed that not only had Jacobs never been employed by the Air Force in the 1960s, but that there was no 1,000-inch telescope at Big Sur at the time (although it was a mobile mounted telescope). The Air Force fraudulently maintained that no Dr Walter F. Manning ever existed, and alleged that no such picture of a UFO was ever taken during any test flight of a missile; in fact, that no such missile system ever existed at Vandenberg Air Force Base.

The Air Force's claims, however, fell flat on the basis of evidence provided to the *Sightings* TV show by Dr Jacobs who has adopted a serious attitude towards revealing the truth about UFOs.

Unfortunately for the US Air Force and its claims about Jacobs, publicly available records do exist which verify that Dr Jacobs was employed by the Air Force at Vandenberg AFB, and was involved in and responsible for filming and developing test-range 'filmography' of the advanced anti-missile missiles of the era. Moreover, records exist of Dr Walter Manning—who is somewhat of a legend in the photo-imaging telescope industry—and of the 1,000-inch Big Sur telescope.

The original film footage of the incident involving the UFO overrunning the USAF anti-missile missile in flight reportedly still exists, but is officially 'missing' or 'sequestered'.

From his archives Dr Jacobs, a photo-reconnaissance film expert, has produced authenticated 35 mm film of the telescope being moved in its trailer to Big Sur, then unloaded and set up by the Air Force under the eye of Dr Manning and Dr Jacobs, as well as film detailing the telescope's test operations (though not yet of the UFO).

In the film, Dr Jacobs and Dr Manning can be seen shooting film with the Air Force at Big Sur in 1964, so there is no question as to their participation and role in the Air Force operation.

Dr Jacobs' involvement in the affair has been authenticated by researchers from the *Sightings* television series, as has his service record which the Air Force continues to deny. The official documents obtained, along with Jacobs' large film library and personal records, prove that Dr Jacobs was involved in this work precisely as he claims.

Because none of the film of the alleged UFO has been released by the Air Force, Dr Jacobs' personal knowledge and eyewitness evidence of this event cannot be verified completely. According to *Sightings*, such appears to be the Air Force's policy regarding this and other such incidents.

However, flying saucers are no longer the province of 'nut cases' and 'schizo-

phrenics': they must be the object of very careful and cautious study by scientists and sociologists.

(Source: *American Computer Company special investigation site, <http://accpc.com/roswell.htm#a0>; posted on ACC Imagine Alien and Science Forum, 14 August 1998)*

VATICAN PRIEST CONFIRMS EXTRATERRESTRIAL REALITY

Readers will recall the item we published in *Twilight Zone* two issues ago (5/04) about Vatican insider Monsignor Corrado Balducci who has proclaimed on Italian television that extraterrestrial contact is a real phenomenon. Now, as we go to press in early September, a recent interview with him is about to be published as the appendix to a new book, *Confirmation*, on the subject of alien abductions.

According to Monsignor Balducci, of the Congregation for the Evangelisation of Peoples, there is no conflict between the Christian faith and belief in aliens. Furthermore, he suggests it is wrong to assert that reports of encounters with aliens are not credible.

"It is reasonable to believe and affirm that extraterrestrials exist," he says. "Their existence can no longer be denied, for there is too much evidence for the existence of extraterrestrials and flying saucers."

In the interview, Monsignor Balducci says that clues such as the existence of UFOs indicate that extraterrestrials are further evolved than humans. He claims that even if extraterrestrials superior to humans were encountered, this discovery would not call into question the teachings of Christianity. He refers to a passage in the New Testament where St Paul refers to Jesus Christ as the King of the Universe, not just the King of the World. "This means that everything in the Universe, including extraterrestrials and UFOs, are reconcilable with God."

A renowned exorcist and expert on demonology, Monsignor Balducci has written two books about the devil. Listed in the Vatican directory as "Priest of Honour" since 1964, he is an official member of the papal household or family.

Monsignor Balducci says his first question to an alien would be about their concept of God. However, he goes on to say: "It is very important to lend credence to the eyewitness accounts, but we must be very careful to ensure that they are authentic. I have also heard of people who have



claimed to have had contacts, but who unfortunately were not mentally sound."

Asked to comment on the interview, a spokesman for the Catholic Media Office in London said: "The fundamental creation message relates to humans here on Earth. If aliens were shown to exist, this would not cast doubt on the veracity of the Gospels. But we would have to ask whether the Christian atonement was applicable to them."

(Sources: Ruth Gledhill, *The Times, UK*; via Gerry Lovell, 29 August 1998, e-mail ed@farshore.force9.co.uk)

ATLANTEAN RECORDS FOUND AT SCOTT STONES, BIMINI

As we've received so many requests for more news of the underwater temple ruins found off Bimini (*T/Zone*, 4/06), we thought we'd publish a recent interview with Mr Aaron DuVal, President of the Egyptology Society in Miami, Florida.

"We have a truly majestic statement to make to the world! It may come as little surprise to some and great surprise to others; some will be jubilant, some will be horrified, and some will be saddened almost beyond words. But, regardless of the jealousies, fears and clambering assumptions, we are pleased and honoured to announce, on behalf of and with the permission of the discoverers, that the Scott Stones are not merely the remains of some ancient and unexpected megalithic society which existed long ago near Bimini, but they are in fact part of the Atlantis of romantic legend—the very Atlantis which Plato described!

"Yes! And the explorers can now prove it! They had already discovered ancient calendars, maps, clay artefacts, etc., but the real clincher to this claim was their discovery of ancient records at the site!

"Once again, according to the explorers, it was the knowledge of Professor Scott (in whose honour the stones were first named) which allowed them initially to locate the actual records—records which can be expected to vastly illuminate our understanding of the earlier days of mankind. And as for any previous presumptions that these ruins might somehow lead to a re-interpretation of the history of civilisation, these presumptions can no longer be looked upon as mere conjecture.

"But you say, 'What, exactly, makes these explorers so sure that *their* find is actually part of Plato's Atlantis?' Well,

their answer is: 'There's a lot of talk these days about the possibility of finding ancient records, especially around Giza, but everyone seems to have forgotten about the original records of Sais.'

"The explorers say they've identified the long-lost chronological records used by the priest of Sais who first informed Solon, back in the sixth century BC. The existence of these records was confirmed, as you may know, following the days of Plato, but they subsequently fell into obscurity. The explorers say they've located and deciphered these very records, and that these Egyptian records correlate with the records found at the Scott Stones! The record is the same, they say, on both sides of the ocean, and the Sais/Solon/Plato account for the end of the Atlantean empire can now be independently confirmed.

"The Scott Stones were discovered some three and one-half years ago, and the explorers themselves had hoped to bring the information to the public last summer. But personal injury, sickness and threats of betrayal severely stalled their original efforts. Now, after months and months of delay, the information is lining up nicely and the discoverers are looking forward to revealing their identities. So, they have tentative plans to try once again this summer, or certainly by the fall, to introduce the information to the public. They have not, as yet, stepped forward personally, simply because they have not wished any hindrance in their ongoing research.

"As for the two sets of records, however, they are still being intensely studied and interpreted. So nothing further will be released, just now, pertaining to these records. But be sure, some very exciting pictures, publications, graphics and videos are already ready, and more are being prepared. And the Egyptology Society in Miami hopes to play a role in bringing this history-shaking information to the fore.

"So the proof is now in. But, of course, Atlantis is a somewhat querulous subject in many circles. And it seems that most of the 'authorities' that have been approached so far have found themselves instantly appalled by the mere thought of such a possibility. Soon, however, some of these 'authorities' may find themselves sorely embarrassed.

"One of the reasons that the Egyptology Society has been included as part of this exciting adventure is that I personally feel, just as the discoverers, that this very precious information should, by all means, completely bypass the contemptuous and doubt-filled 'established order'—until such time as all the evidence has been fully prepared for the slaughter!"

Mr DuVal says the Egyptology Society will forward updates to *NEXUS Magazine* as they become available.

(Source: Interview with Mr Aaron DuVal, conducted 23 May 1998 by the Egyptology Society, c/o Miami Museum of Science, 3280 South Miami Avenue, Miami, Florida 33129, USA)



ALIEN HEALINGS

— The Medical Evidence —

Some people who have had close encounters with UFOs and alien beings have experienced sudden and miraculous healings of their chronic health problems.

by Preston E. Dennett ©
1996, 1998

6815 Remmet Avenue #322
Canoga Park, CA 91303, USA
Telephone: (818) 348 3892

Despite the fleeting nature of UFOs, UFO investigators have managed to collect a vast amount of evidence including eyewitness testimonies, photographs, moving films, radar returns, metal fragments, landing traces, medical effects, electromagnetic effects, animal reactions and thousands of pages of government documents. But in spite all this evidence, there are still many sceptics. Indeed, we are all waiting for the 'smoking gun' that will prove conclusively the reality of UFOs.

One form of evidence that can literally make or break a case is medical evidence. For the most part, study of these types of effects has been limited to injuries received as a result of a UFO encounter, and little attention has been paid to the positive effects.

But as it turns out, there are now over 100 documented cases of UFO healings on record. A UFO healing can be defined as a positive physiological reaction as a result of a UFO encounter. And as it turns out, virtually every major UFO investigator has uncovered cases of this type.

So, are UFO healings the 'smoking gun'? Are they the best evidence to convince the world that UFOs are here? There is a huge amount of evidence to support UFO healings, but what exactly is the 'best' evidence? Should the cases with the most reputable witnesses be given the highest priority? Or the multiple-witness cases? Or perhaps the cases with before-and-after diagnosis from medical doctors? And what about cases with little supporting evidence other than the witness's claim to have been healed by aliens, with all traces of the disease gone? The ideal case would contain all these elements. However, things rarely happen that way in the real world. UFO investigators are limited to trying to put together a huge jigsaw puzzle, and most likely with half the pieces missing!

With more than 100 cases of UFO healings, it shouldn't be too hard to come up with some solid cases. What follows are ten of what I believe to be among the strongest cases to support UFO healings. Each has been chosen for different reasons.

CASE #011: Cancer

This 1957 case was first revealed by Brazilian journalist João Martins and UFO investigator Olavo T. Fontes who was the official medical investigator of UFOs for the Brazilian Government.

According to the report, the daughter of a powerful and important man was suffering from stomach cancer. Doctors expected she would die. Then, in full view of her family and the maid, the young girl was healed by aliens. The case would never have seen the light of the day had not the maid of the family written a letter to a UFO investigator. What follows is a portion of the letter:

"...I personally witnessed the incident here related. I don't know if you will believe me, but I assure you that what I am going to tell you is the truth... The daughter of my employer suffered from cancer of the stomach. She suffered considerably, and I was employed to serve as a sort of governess and to assist the Señorita Lais, the daughter with cancer...

"I remember the night of October 25 very well. We expected her to die, as the pains of Señorita Lais were terrible. The injections seemed to have no effect. Her father was singing a verse, when suddenly a strong bright light came on to one side and shone directly on the house. We were all in the room of Señorita Lais whose window was situated exactly on the side of the house from which the light came. The only light inside was a small lamp at the head of the bed.

"'Look,' cried Julinho, a brother of the dying girl, as he ran to the window and saw a disc-shaped machine there in the light. It was not very big, and I am not learned enough

to be able to say what its diameters might be or its height. I know that it was not very big...

"Suddenly, a port automatically opened in the object and two small beings emerged. They came towards the house, while a third one remained in the port of the disc...

"They had something on their hands that I thought were gloves. Their suits were white and seemed to be thick; the chest, the sides and the cuffs shined brightly. I do not know how to explain. They came up to the side of Señorita Lais who moaned in pain, eyes wide open and not understanding anything that was going on around her...

"Those 'humans' looked at me silently and stood at the side of the bed and Lais, placing the instruments they carried on the top of the milky coverlet. They made a gesture towards my employer, and one of them placed his hand on the forehead of Sr X. and 'discussed' the case of Señorita Lais with a bluish light that showed all of her interior. We saw all there was inside the belly of the girl. With another instrument that emitted a noise, 'he' pointed it in the direction of the stomach of Lais and we could see the cancer. The operation lasted about a half-hour... Then 'they' gave [Sr X.] a sphere made of stainless-steel-like metal which contained some 30 small white pills. She was to be given one per day and she would be cured.

"Lais later returned to her doctor who verified that *her cancer had been cured...* [Author's emphasis added.]

"Lais was condemned to die of cancer of the stomach, and in spite of this she was saved by an instrument that looked like a flashlight, that emitted rays that 'dissolved' the cancer, and she survived. They saved Señorita Lais and the same night returned to the flying machine and were gone."

This case is significant for many reasons. Firstly, it was one of the first reported UFO healing cases ever released to the public and therefore could not have been influenced by earlier reports. Secondly, the incident was witnessed by an entire family and the

maid. Thirdly, a patient who was diagnosed with terminal cancer miraculously survived, evidently as a result of the UFO encounter. She was diagnosed afterwards as being free of cancer, which, of course, cannot be faked.

Another interesting aspect of this case is the physical evidence obtained. There are at least two other cases on record in which people were given medicine by aliens. In each case, samples of the medicine were saved for analysis.

Probably the most important aspect of this case is the obvious sincerity of the letter. This is obviously a complex case, and stands as one of the pioneering cases of UFO healings.

CASE #016: Diphtheria

This case was originally revealed by David Jacobs, PhD, in his book, *Secret Life*. The main witness used the pseudonym Lynn Miller but has now released her real name, Alice Haggerty.

In 1962, at the age of six, Alice was struck with diphtheria, an often fatal disease. Because of a religious background, she had not been vaccinated against the disease. For the same religious reasons, her parents refused to take her to hospital. They did call in a doctor who said that Alice's condition was very serious. Still, Alice's parents refused to listen.

Over the next two weeks, her condition deteriorated. The doctor visited daily, and at the end of the two weeks he told Alice's mother that he did not expect Alice to live through the night.

Alice, however, happened to be an abductee, and would eventually have several abduction experiences throughout her life. On the evening in question, Alice was apparently abducted by friendly aliens whom she described then as "angels in white robes with silver belts". She remembers being transported inside a UFO where the aliens told her she would be cured. They waved a small "rodlike device" around her body, and then made her stand inside a "large blue cylinder" with a little window. The aliens watched as a bright light was emitted from the top of the machine until it was about eight inches from the top of her head. The light then retreated and Alice was instructed to exit the cylinder.

According to Jacobs, the aliens "informed her in a matter-of-fact manner that she was now cured and 'cleansed'". Alice then underwent more of the typical procedures that are often performed aboard UFOs. The next morning, her mother found her playing on the floor as if everything was normal. Her mother and the doctor ordered her into bed, but they both admitted that *the diphtheria was completely and totally gone*.

This case is important for obvious reasons. Firstly, here is a young girl diagnosed by a doctor as having an advanced case of diphtheria. On the edge of death, she has a classic UFO encounter. The next morning, a few hours after the encounter, she is diagnosed by her doctor as being completely free of the disease. Furthermore, the witness can distinctly recall the procedure which rid her of the disease. This is the type of proof that just cannot be ignored.

This case is also supported by the fact that it has been exhaustively investigated, not only by David Jacobs but by the witness herself. As the only reported healing case involving diphtheria, it is also unique and important.

On the edge of death, she has a classic UFO encounter. The next morning, a few hours after the encounter, she is diagnosed by her doctor as being completely free of the disease.

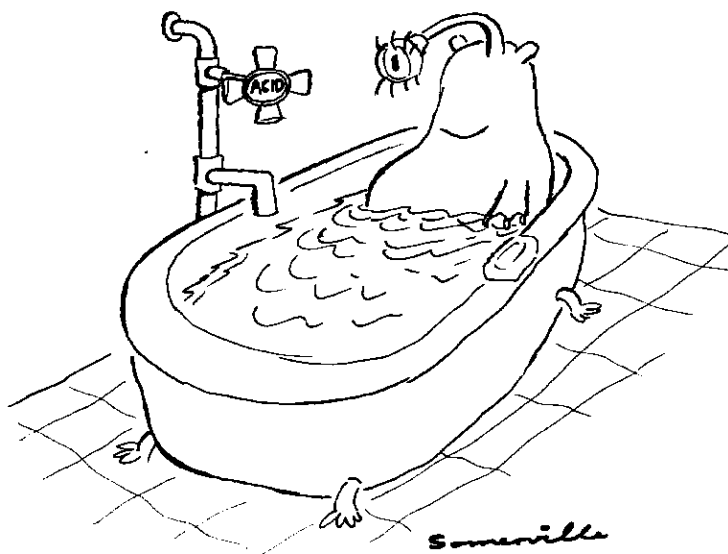

CASE #017: Flesh Wound

This case has been told and retold in numerous UFO books and articles and remains one of the all-time classic cases of UFO healings. On September 3, 1965, two police officers, Patrol Deputy Robert W. Goode and Chief Deputy Billy McCoy, were driving near Damon, Texas, when they both spotted a solid object with coloured lights rise up and hover overhead.

Suddenly, the unidentified object moved over the car and cast down a beam of light which struck Goode on his left arm. (Two days earlier, Goode had been bitten on his left index finger by his son's pet baby alligator. At the time of the UFO incident, the finger was swollen, painful and bandaged.)

"The inside of the car was lit up by the bright light," Goode said. "I could feel the heat from the light. We got out of there."

The two officers raced away in terror.

Afterwards, Goode noticed that his finger was no longer throbbing with pain. "I suddenly realised it was not bothering me and I pulled it out of the bandage. Hell, you couldn't tell I had ever been bit," he said.

Chief Deputy McCoy verified Goode's story. "*The swelling had disappeared and the finger looked a lot better,*" he noted.

The two deputies later returned to the scene and, to their surprise, found that the UFO was still there. They eventually reported the sighting to the Air Force and were extensively interviewed by Major L. R. Leach, of Ellington Air Force Base, who concluded that the officers had in fact encountered an unidentified flying object. The press caught wind of the incident, and soon the two officers were besieged and their story became very well known.

This case is important not only because of the high reliability and good reputation of the police officers, but also because the case was fully investigated by a Major from the Air Force who could find no flaws in their account. Again, it would be folly to ignore such strong evidence.

CASE #019: Liver Hepatitis

This next case is compelling for many reasons. On December 7, 1967, Danish investigator Hans Lauritzen and four colleagues were conducting an active investigation of UFOs. Their research had led them to participate in routine skywatches to observe UFOs firsthand, rather than just investigate reports of sightings.

In February 1966, Lauritzen had contracted a severe case of liver hepatitis and had to retire and go on a pension. At the time of the UFO watch, Lauritzen was not only extremely weak and tired but his liver was increased in size by 10 centimetres.

Just before ending the skywatch on December 7, the five investigators were surprised to see two "great, dim, yellow globes about a hundred yards away from them". Lauritzen immediately became entranced. He then walked away from the group and had a telepathic communication with the UFO occupants. He was told in part that he has great power to help people.

Afterwards, Lauritzen came out of his trance and heard his friends calling. He ran towards them and noticed immediately that his health had dramatically improved. "I ran and ran so fast," he said, "that my four friends could not follow me. I had to wait for them. I realised I had been cured of my hepatitis."

Wisely, Lauritzen went to his doctor and was pronounced totally free of his disease. "I passed a medical examination," he said, "not mentioning my contact, of course; and *to the surprise of the doctors, 10 centimetres of my liver had disappeared so that it was now normal size.* The blood test showed that it functioned now as any other healthy liver...before I had a sick liver. At one time it was as much as 16 cm too large. Now I have a healthy liver. I am most thankful to the UFO for having cured my otherwise chronic disease... I swear to God that I have told the truth as far as I can see it."

This case is unique among UFO healing cases in that it was a UFO investigator who received the healing. Again, it shouldn't be taken lightly that a so-called 'chronic' condition disappeared as a direct result of a UFO encounter. The fact that the encounter was witnessed by four other people also lends considerable credibility to the account. And, of course, there is the obligatory doctor's examination which all but proves that something highly unusual occurred.

CASE #021: Flesh Wound and Partial Paralysis

Most of the healing cases occur to people who have little or no medical training. However, that is not always true. In this next case, it was a doctor who experienced the cure.

On November 2, 1968 in the French Alps, an anonymous doctor was awoken just before 4.00 am by the cries of his infant son. Upon investigation, the doctor saw two luminous discs hovering outside his son's bedroom. As he watched, the two discs converged into one and then emitted a powerful beam of

light which struck the doctor on the front of his body.

At the time of the incident, the doctor was suffering from a partial paralysis of his right arm and leg caused by injuries received many years earlier during the Algerian War. The doctor was also suffering from a recent flesh wound on his ankle. He had been chopping wood three days earlier when the axe slipped and gouged deeply into his ankle, which was still swollen and painful.

After being struck by the beam of light, the doctor was dazed and shaken. He woke up his wife and told her what had happened. She instantly noticed that her husband's *ankle wound had "completely disappeared"*. It was the next morning that the doctor realised *he no longer suffered from any type of paralysis and he no longer walked with a limp.* He was even able to take up piano-playing again, having been an accomplished player before his paralysis.

This case is important not only because it occurred to a doctor, but because the cure was verified by an independent witness immediately after it had occurred.

This case is important not only because of the high reliability and good reputation of the police officers, but also because the case was fully investigated by a Major from the Air Force who could find no flaws in their account.

CASE #029: Teeth

This next case is highly credible because of the huge amount of physical evidence. On December 30, 1972, nightwatchman Ventura Maceiras of Argentina witnessed a bright light hovering above his home. Inside the light, he was able to discern a metallic craft with portholes. At this point, Maceiras was struck by a "brilliant flash of light" which shot out from underneath the craft.

For weeks following the encounter, Maceiras suffered from a number of alarming symptoms which seemed to indicate radiation poisoning—symptoms including hair loss, headaches, nausea, diarrhoea, eye irritation and "swollen red pustules" on his neck. Doctors were baffled, but, when Maceiras explained that the symptoms were caused by his UFO encounter, they had no choice but to believe him. His symptoms simply could not be faked.

There was a huge amount of supporting physical evidence. The tops of the hundred-foot-tall eucalyptus trees were scorched where the object had hovered. Maceiras' cat disappeared in full view when the beam came out of the craft; 48 days later, the cat reappeared with severe burns on its back. An abnormally large number of mysteriously dead catfish were found in a small stream at the exact location of the sighting.

There was so much physical evidence that the case attracted considerable attention from various officials. In a period of less than a month, Maceiras was interviewed over 60 times by multiple officials including doctors, police, government officials, UFO investigators and others.

Maceiras took weeks to recover from his injuries caused by the UFO. Then, less than two months after the encounter came the final but most incredible symptom of all. As verified by doctors, engineers, police officers and professional UFO investigators, *Maceiras, although 73 years old, began to grow his third set of teeth.*

UFO investigator Pedro Romaniuk was assigned to the case because of his high credentials as a former commander with an international airline and a technical investigator for the Argentine Air Force Aviation Accidents Investigation Board.

Romaniuk performed a follow-up visit to check up on Maceiras' physical condition. As Romaniuk noted: "Since approximately February 10, Maceiras has observed that new teeth have been appearing in his upper left gum. At the time of my visit, I was able to confirm that two front teeth and two cheek teeth were coming through and were approximately 2 mm to 3 mm long."

This case is significant not only because it has a huge amount of supporting physical evidence, but it is also one of the most exhaustively investigated cases in the history of ufology. The case is so well verified that it remains an undisputed classic case and has been reported in countless UFO publications.

CASE #054: Integumentary System

This next case was included because of the obvious sincerity of the witness, the dramatic physiological improvements caused by the encounter, and because it was a multiple-witness case.

On March 20, 1988, Professor of Indian Studies at the University of South Dakota, John Salter, Jr (aka John Hunter Gray) and his son were driving near Richland Center, Wisconsin, late at night when they both experienced a close-up UFO sighting

followed by a period of missing time. They both recalled being examined by aliens. Salter also recalled being injected with needles as he lay on the examination table.

Almost immediately after the encounter, Salter began to notice a number of remarkable physiological changes. In fact, the changes were so apparent that Salter carefully tracked them and noticed *improvements in over 18 areas* including "improved skin tone, circulation, eyesight, faster blood-clotting after cuts and scratches, and faster and thicker growth of toenails and hairs". And that's not all. Salter also reported: "...many facial wrinkles have disappeared and others are fading; my face has narrowed and my neck area has slimmed (as has my entire body to some extent) and none of this has involved 'sagging'. My circulation has improved. Cuts clot immediately and heal very quickly; my energy level is way up; and I've had no colds or flu or any other illnesses since March 1988... [and] after all these years, I have a five o'clock shadow."

Although Salter did not rush to a doctor for a diagnosis, his improvements were easily noticed by all who knew him. His son also reported several similar physiological improvements.

Salter has been very active in the civil rights movement and is a widely respected UFO researcher in his own right. The huge number of physiological improvements, the obvious sincerity of the witness and the fact that the encounter had multiple witnesses all combine to make this one of the most astonishing and credible UFO healings on record.

CASE #071: Cyst

Some of the most convincing forms of evidence come from doctors' diagnoses, and this is just one of the reasons this case is included here.

In 1991 in Atlanta, Georgia, abductee Alicia Hansen (pseudonym) was diagnosed with a cyst. She was scheduled to have it surgically removed. However, before her doctors could perform the operation, she had a close encounter of the healing kind and *her cyst mysteriously disappeared.*

As Alicia explained: "...I was really worried about the cyst... I had already been diagnosed with the cyst by the doctors. I was having a lot of problems with it, too. They did an MRI where they take a picture and look at the cyst. So they saw the cyst and I was going to go back and have surgery on it."

Shortly before her surgery, Alicia had partial memories of an encounter. Then when she went to the hospital to have the cyst removed, she received quite a surprise.

"So I went back to the hospital to get another MRI done and make sure everything was okay. And the nurse said, 'Well, this is so strange'—not the nurse but the person who reads the picture. They said, 'This is really weird because if we didn't know any better, we'd say that you never had a cyst. But what's going on here is there's fluid in your Fallopian tubes. And the fluid, right where the cyst was—this fluid is not present when it ruptures. This is a fluid that is usually present after surgery...' So it completely looked as if I'd had surgery done, and I didn't."

This type of medical evidence is virtually undeniable. Alicia had been diagnosed with a cyst, and then the cyst had not only mysteriously disappeared, but there was physical evidence that

"They said, 'This is really weird because if we didn't know any better, we'd say that you never had a cyst. But what's going on here is there's fluid in your Fallopian tubes. And the fluid, right where the cyst was—this fluid is not present when it ruptures.'"

she had had surgery, and yet she hadn't. At least not by Earth doctors!

Alicia has had several other similarly remarkable healings. Furthermore, she has multiple witnesses to many of her encounters. There is simply no explanation for the fluid in her Fallopian tubes, other than surgery.

CASE #078: Tumour

This next case was investigated by highly respected UFO researcher William Hamilton, Jr. What makes this case remarkable is that there was a before-and-after diagnosis and the witness was able to obtain her medical records from her doctor, proving that something very unusual had occurred.

Morgana van Klausen (pseudonym) from southern California has had several close encounters through the late 1980s and early 1990s. On December 4, 1994, Morgana went to the doctor and discovered that she had an unwelcome tumour in her right breast.

According to Bill Hamilton: "An X-ray found a peculiarity in the axillary segment of the right breast. This was followed by an ultrasonography over the same area. A small non-cystic mass measuring 1.6 by 0.6 cm was found in the problem area."

Surgery was scheduled for December 14. A day before the surgery, on December 13, Morgana was driving with her son when they both saw a "white, triangular shaped craft" hovering nearby. Her son cried out: "Mom, look! Wow, this is a good sign. They are protecting us. We are protected. You wait and see. You'll have no more problems!" Those turned out to be prophetic words.

That evening, Morgana was overcome by intense pain in the area of the mass. She tried to get up out of bed, but was unable to move and then lost consciousness.

The next morning she went straight to the doctor to have her surgery. At the hospital, the doctor inserted a needle into the mass and took another X-ray. To everyone's surprise, *the new X-ray showed that there was no mass.* The old X-ray was retrieved which clearly showed the mass. Another ultrasound was ordered, which confirmed that the mass had disappeared.

Hamilton reported: "Both the radiologist and the surgeon confirmed that the previous diagnostic had revealed a solid mass, and that solid masses just don't disappear."

Here again we have before-and-after diagnostics as well as confirmation by a radiologist and surgeon which all but prove that surgery must have occurred.

CASE #089: Colour Blindness

This next case again provides definite proof of a UFO healing, not only because a chronic condition disappeared as a direct result of a UFO encounter but also because the healing was confirmed by the witness's doctor.

Eddie X. is a gentleman from the mid-western United States who had gone to UFO investigator John Carpenter to explore his many abductions. While the investigation was ongoing, Eddie X.

continued to have encounters.

"During a physical examination by the beings," Carpenter said, "Eddie's right eye was removed. He felt it pulled out and replaced. Afterwards there was a redness, a physical soreness. He did not feel they were implanting anything behind his eye, only that they were 'fixing' him. The side benefit of this operation appears to be enhanced colours. The procedure was clearly for their purposes, not for Eddie's, but the *partial accidental cure of his lifelong colour-blindness* was a side effect."

Carpenter further substantiated the healing by obtaining a statement from Eddie's eye doctor, which said that Eddie suffered from "profound color blindness", though after his experience his vision "had improved up to green color blindness".

Carpenter's claim that the healing was "accidental" seems to be nothing more than pure speculation. What is an undeniable fact, however, is that the cure of a chronic condition was verified by a medical doctor. Again, how can something like this be explained, bearing in mind that the UFO aspect cannot be pushed aside?

MORE MIRACULOUS UFO/ET HEALINGS

The above ten cases are among the best evidence for UFO healings. However, they are by no means the only highly credible cases. Many other cases could just as easily have been included. It all depends on what one considers to be the 'best' evidence.

For example, nearly all cases involving healings of cancer and/or serious/chronic conditions are particularly impressive. If one is diagnosed as suffering from a chronic condition or fatal disease and then has a UFO encounter and is subsequently diagnosed as free of the condition/disease, is this not compelling evidence of a UFO healing?

Several witnesses also claim to have got hold of their before-and-after medical records which conclusively prove that they were in fact healed. Anecdotal evidence can also be very strong—certainly strong enough to convict somebody in a court of law. And if one case falls short in some aspect of evidence, there is always another case waiting to fill the niche. Isn't the fact that so many healings are being reported, strong evidence in itself?

There are countless other cases which have a stunning amount of evidence. Take the case of Ludwig Pallman who was cured of liver disease by an alien who visited him in his hospital room. Said Pallman: "All of this may be checked by any one of my readers. I became the miracle patient of the famous Maison Française Hospital in Lima, Peru." After Pallman's cure had been effected, his doctor told him: "You're fit as a flea....this is really baffling. Yesterday you were a very sick man, and today you seem to be a different person."

Or take the case of an anonymous gentleman from Finland who suffered from a congenital defect which left his liver abnormally enlarged—that is, until he had a close-up UFO encounter. The report on the case reads: "During this examination, the doctors

Take the case of Ludwig Pallman who was cured of liver disease by an alien who visited him in his hospital room.

Said Pallman: "All of this may be checked by any one of my readers. I became the miracle patient of the famous Maison Française Hospital in Lima, Peru."

Continued on page 90



REVIEWS

BOOKS

Reviewed by Ruth Parnell

POSITIVELY FALSE: Exposing the Myths Around HIV and AIDS

by Joan Shenton

Publisher: I. B. Tauris & Co., UK, 1998
ISBN: 1-86064-333-7 (291pp hc)

Price: AUD\$ n/a; £17.95; USD\$29.95
Available: **Aust**—Harry Howell, tel (02) 9427 2830; **UK**—I. B. Tauris & Co. Ltd, tel 0171 831 9060; **USA**—St Martin's Press, tel (212) 674 5151, 1800 321 9299

Opponents of the 'HIV = AIDS = Death' hypothesis are gaining voice within the scientific and medical communities, while millions of dollars are still being directed into the research, development and marketing of drug therapies like AZT which has already been proved to have fatal effects.

One maverick medical journalist, British award-winning documentary filmmaker Joan Shenton, has been tracking the controversy between the HIV/AIDS orthodoxy and its detractors for over a decade, and her book, *Positively False*, is a record of her investigations into this ongoing battle royal.

The leading light of dissent is microbiologist Dr Peter Duesberg who first went public in 1986 with his refutation of the 'HIV causes AIDS' hypothesis. His conclusion, that HIV is nothing more than inactive genetic fragments that cannot possibly cause AIDS, seems to have been vindicated as more scientists realise that HIV has never been isolated. His belief that AIDS is the result of immune system breakdown caused by toxic overload from drug abuse, pharmaceutical drug 'treatments' and impure blood-clotting

factors in transfusions has been vehemently put down by scientists and drug companies with vested interests in anti-AIDS drugs, test kits and their own egos.

Not only has promising scientific enquiry been sidelined in the name of profit and reputation, but many thousands in the industrialised West and Third World have died due to misdiagnosis and misprescribing.

CONVERSING WITH THE FUTURE: Visions of the Year 2020

by Jenna Catherine

Publisher: Wild Flower Press, USA, 1998
ISBN: 0-926524-45-3 (222pp tpb)

Price: AUD\$29.95 + \$7.50 p&h; £12.99; NLGf n/a; USD\$16.95

Available: **Aust**—Bhudevi, tel (07) 5534 9200; **UK**—Counter Culture, tel 01823 698895; **Europe**—NEXUS office; **USA**—Access Publishers Network, tel (616) 276 5196

When we think about our concept of 'the now' and our place in it, we tend to think in terms of the past and present. But to imagine that our totality includes ourselves in the future puts a whole new spin on reality. This is the basic premise of *Conversing with the Future*, the jumping-off point for author Jenna Catherine in her own mind-travelling forays into the future.

As an experiment, Catherine chose the year 2020 as her destination, and with the help of a spirit guide and people from present and future time zones she discovered a Utopian society based on love. It is a world where telepathy is the norm, but it's a type that incorporates expansion of the physical senses, fluid energy flow and dynamic resonance—and Catherine includes guidelines

on how to develop these abilities.

By the year 2020 we have learned how to open our hearts and be more intuitive, sensual, happy, humorous, generous and respectful. Fear only gets a look-in when viewed as an opportunity for emotional growth.

Mental health has become 'mindcare' and people can visit clinics where they hook into 'light machines' to enhance their knowledge and intuition. Relationships and family life, education, entertainment, communication, business and economics have all undergone fundamental positive shifts by 2020, according to Catherine's visions.

So how do we get to this future paradise? Catherine suggests we should imagine it as achievable and connect with it as though it were already a reality. As for what happens in the meantime, we are left none the wiser.



REVIEWS



BOOKS

HAARP: The Ultimate Weapon of the Conspiracy

by Jerry E. Smith

Publisher: AUP, USA, 1998

ISBN: 0-932813-53-4 (256pp tpb)

Price: AUD\$30.00; NZD\$ n/a; £13.50;

NLGf n/a; USD\$14.95 +p&h

Available: **Aust/NZ/UK/Europe**— NEXUS offices (see page 2 for details); **USA**—

Adventures Unlimited Press, tel (815) 253 6390, fax (815) 253 6300

One of the most controversial experiments in the history of the world is to go fully on line in 1999. But is the High-frequency Active Auroral Research Program (HAARP), based at Gakona, southwest Alaska, just a Big Science project or a Big Military project that is part of a New World Order conspiracy? According to author Jerry Smith in this latest book on HAARP, the latter is the case, and he devotes much space to examining why. The scientists who have the 'official' job of using the antenna array to research the aurora borealis seem to be ill-informed of the alleged military agenda and its awesome potential to inflict great harm on this planet and its inhabitants.

In this comprehensive treatment, *HAARP: The Ultimate Weapon of the Conspiracy*, Smith analyses HAARP's background in terms of Tesla technology, the Bernard Eastlund patent for altering the Earth's atmospheric, ionospheric and/or magnetospheric regions, and electromagnetic warfare between the ex-USSR and the USA. He asks whether HAARP is 'science out of control' or a 'Star Wars' project, and warns that it may contravene international treaties.

Apart from one overt military purpose of facilitating communication with submarines, research suggests that the HF and ELF waves that HAARP can broadcast are capable of modifying the weather and altering the mental states and behaviours of entire populations. Yet even the military can't say what will happen when gigawatts of energy are focused on the ionosphere. Smith urges that we need to encourage debate and lobby governments and agencies—whether we want to stop the project or at least insist that appropriate safety controls are put in place.

VITAL SIGNS

by Andy Thomas

Publisher: S B Publications, UK, 1998

ISBN: 1-85770-155-0 (144pp tpb)

Price: £12.95; NLGf n/a; USD\$20.00

Available: **UK/Europe**— NEXUS offices;

USA—New Leaf, tel 1800 326 2665

Crop circle enthusiasts in England

wait in eager anticipation every spring and summer to see what artistic and geometric wonders will be etched in Zen-like impermanence across the fields. But so do the debunkers. Sadly, the hoaxing scandals of recent years have diverted serious public attention from the mysterious phenomenon.

In his third book, *Vital Signs*, Andy Thomas appeals to people who may be quite sceptical about crop circles but retain some spark of curiosity that can be rekindled. He presents a brief history of the phenomenon, including scientific, statistical and geometric analysis of various examples, backed up with b&w photographs and diagrams plus a separate section of

colour plates. He then explores other anomalous evidence—e.g., records of accompanying strange lights and sounds, and reports of 'missing time' and physical/psychological effects within these glyphs—which may assist our eventual understanding of the complete picture.

So, based on the available evidence, if only a fraction of crop circles are hoaxes, how did they get there? Who or what is responsible for creating them? Thomas considers a number of hypotheses such as natural Earth forces, nature spirits, extradimensional/terrestrial intelligences and even human psychic interaction, and suggests the phenomenon has already had quite a transformative effect on sections of humanity. The meaning of these glyphs may still be eluding our conscious minds, but can we say absolutely that we're *not* being affected subconsciously and collectively? (See our pick of the 1998 UK crop in this issue.)





REVIEWS

BOOKS

FORBIDDEN ARCHEOLOGY'S IMPACT

by Michael A. Cremo

Publisher: Bhaktivedanta Book Publishing, USA, 1998

ISBN: 0-89213-283-3 (569pp hc)

Price: AUD\$ n/a; NZD\$ n/a; £27.50;

NLGf n/a; USD\$35.00; CAD\$50.00

Available: **Aust**—Gemcraft, tel (03) 9888

0111; **UK/Europe**—NEXUS offices; **USA**—Torchlight Publishing, Inc., 3046 Oakhurst Avenue, Los Angeles, CA 90034, tel 1888 867 2458, www.torchlight.com

Few books have attracted as much vehement attack and glowing praise as *Forbidden Archeology*, written by Michael Cremo and Richard Thompson. This exhaustively researched 900-page book documents the considerable anomalous evidence for extreme human antiquity that has been gathered over the last century or so but suppressed by mainstream scientists because it conflicted with the prevailing paradigm about our origins and history.

The reactions to the 1993 release of this book, and to the 1996 NBC broadcast of the documentary *Mysterious Origins of Man* (which featured Cremo), came from both mainstream and maverick scientists and historians as well as creationists, conspiracy theorists, schoolteachers and ufologists. Some found the information threatening; others considered it revelatory. The authors were surprised at the variety and intensity of the reactions, and Cremo suggests that the book had struck "a sensitive spot at some deep level of the modern psyche".

So, for the sake of posterity and in the interests of scholarly enquiry, Cremo has compiled this material into another book of forbidding size: *Forbidden Archeology's Impact*. It contains journal articles and transcripts of papers Cremo has delivered on the first book; reviews published in academic and non-academic publications; Cremo's responses to negative criticism, which journals refused to print; selected correspondence with scientists, philosophers and other interested parties; and transcripts of radio and television interviews as well as Internet exchanges about the book. This is an important sourcebook for what it shows of the 'knowledge filter' in action.

MAYA COSMOGENESIS 2012

by John Major Jenkins

Publisher: Bear & Co., USA, 1998

ISBN: 1-879181-48-7 (431pp tpb)

Price: AUD\$39.95; NZD\$52.95; £14.99;

NLGf n/a; USD\$20.00

Distributors: **Aust**—Gemcraft, tel (03)

9888 0111; **NZ**—Peaceful Living, tel (07)

571 8105; **UK**—Airlift Book Co., tel 0181

804 0400; **Europe**—NEXUS office, tel +31

(0)321 380558; **USA**—Bear & Company

Publishing, tel (505) 983 5968, 1800 WE-

BEARS, fax (505) 989 8386

Why did the Maya choose the date of 21 December 2012 to mark the end-time of their long-count calendar? And why mark the (northern) winter solstice?

Studying the star charts, independent scholar/author John Major Jenkins noted that a very rare alignment in the precessional cycle will occur on the December solstice in 2012, when the sun conjuncts the centre of our Milky Way galaxy. Seasonal alignments occur once every 6,450 years, but this

December solstice of 2012 occurs once every 25,800 years! Jenkins surmised that the Maya, like many other ancient cultures, were aware of precessional cycles, but it was no coincidence that they marked this date. Indeed, as he discovered, it was central to their cosmology, mythology and calendars, as was the idea of galactic centre as the source of life. The Maya even had a glyph to represent the black hole at galactic centre—the existence of which has only recently been confirmed by astronomers.

In his expansive new book, *Maya Cosmogenesis 2012*, Jenkins explains how the Maya revered the end-time as a zero point, entered through galactic centre and involving an energy field-effect reversal and rebirth into a new World Age. In explaining his thesis, he takes us on a heady trip through Maya shamanic rites, the origin and

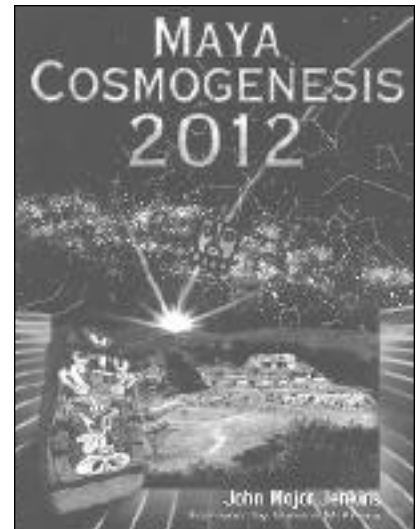

REVIEWS



BOOKS

development of the long-count calendar at the sacred site of Izapan, the galactic geometry and symbolism of the ball court, and much more. Jenkins' findings not only extend our understanding of Maya cosmology; they have great significance for humanity at the evolutionary crossroads.

MY SEARCH FOR TRACES OF GOD by Philip S. Callahan, PhD

Publisher: *Acres USA*, USA, 1997
ISBN: 0-911311-54-8 (215pp tpb)
Price: AUD\$39.00 including p&h;
USD\$18.00 (USA p&h add 10%; foreign
p&h add 20%)
Available: **Australia**—*Acres Australia*, tel
(07) 5449 1884, fax (07) 5449 1889;
USA—*Acres USA*, PO Box 8800, Metairie,
Louisiana 70011, tel (504) 889 2100,
1800 355 5313 (toll free in USA), fax (504)
889 2777

One of this age's remarkable men is Dr Phil Callahan, a scientist-philosopher who has dedicated his life to understanding Nature and how God's plan is enacted through it. His latest book, *My Search For Traces of God*, is a very touching, personal memoir wherein he records the formative experiences that sparked his explorations into the physics of Divine Providence.

Serendipitously, Dr Callahan spent some of these formative years as a US serviceman and radio technician in wartime Ireland where he had profound insights into Nature, e.g., the role of insect antennae as frequency tuners, and of the Irish round towers in amplifying Earth energy and utilising soil paramagnetism for the benefit of agriculture

and the people. Dr Callahan has detailed these discoveries and more in other books and papers (a complete list of these is printed herein), but his aim here is to present personal vignettes in the hope of transmitting a sense of the sacred to the reader.

Dr Callahan's eco-ethical quest is imbued with a religious fervour, which may help explain his interest in the scientific analysis of Virgin Mary sightings around the world. Such apparitions tend to occur in highly paramagnetic locations, and it's no accident that sacred monuments and places of worship are sited in similarly highly charged areas. His treasure-trove of research, from his experiments with the candle flame's far-infrared spectrum radiation to the sine-wave dynamics of space-time, has far-reaching implications for our understanding of life and our place and purpose in the Universe.

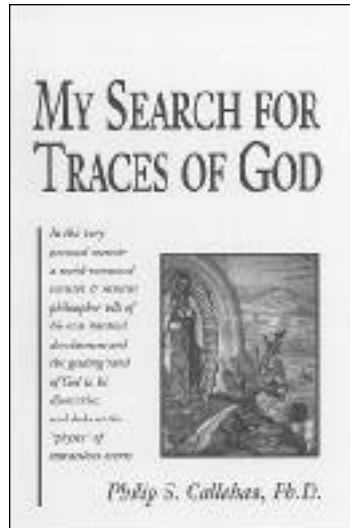

THE GIZA POWER PLANT: Technologies of Ancient Egypt by Christopher P. Dunn

Publisher: *Bear & Co.*, USA, 1998
ISBN: 1-879181-50-9 (288pp tpb)
Price: AUD\$36.95; NZD\$47.95; £12.99;
USD\$18.00

Distributors: **Aust**—*Gemcraft*, tel (03)
9888 0111; **NZ**—*Peaceful Living*, tel (07)
571 8105; **UK**—*Airlift Book Co.*, tel 0181
804 0400; **USA**—*Bear & Co. Publishing*,
tel (505) 983 5968, fax (505) 989 8386

It was back in 1977, after reading Peter Tompkins' book, *Secrets of the Great Pyramid*, that Christopher Dunn (a UK-born, US-based master craftsman) first embarked on his own quest to unravel the Pyramid mysteries. Studying the edifice with an engineer's eye, he was impressed by how much the schematics reminded him of a machine—a very big one, at that. Twenty years later, his theories form the basis of his book, *The Giza Power Plant*.

Dunn's premise is that the Great Pyramid was actually a power-generating complex, the King's Chamber being its power centre and the Queen's Chamber its hydrogen fuel production centre. He deduces that the early Egyptians (or their predecessors) found a way of converting the Earth's resonant or vibrational energy into microwave energy by way of a combined chemical reaction and acoustic filtering technique, but to achieve this the Pyramid had to be built to exacting specifications. Of course, the cutting and polishing of their stone blocks and artefacts also required precision craftsmanship with advanced tools and techniques which are yet to find their way into the archaeological record. That the King's Chamber is a resonant structure has been noticed by other



REVIEWS

BOOKS

researchers, but this engineer has worked out, in theory, how the entire monument operated.

As for how the Egyptians would have transmitted or used the energy they generated is difficult to determine as few clues remain; but Dunn speculates that they may even have used it to power interplanetary spacecraft! This is an intriguing study that will help rewrite the Egyptian textbooks.

THE MARS MYSTERY

by **Graham Hancock, Robert Bauval and John Grigsby**

Publisher: Michael Joseph Ltd, UK, 1998; Crown Publishers, USA, 1998 (Hancock by-line only)

ISBN: 0-7181-4314-0 (hc, UK), 0-7181-4354-X (374pp tpb); 0-609-60086-9 (344pp hc, USA)

Price: AUD\$24.95 (tpb); NZD\$49.95 (hc), NZD\$29.95 (tpb); £16.99 (hc); USD\$26.00 (hc)

Distributors: **Aust/NZ**—Penguin Books; **UK**—Bookshops; **USA**—Random House

There is much more in this book than is even implied in its title, *The Mars Mystery*, for it speculates on a catastrophic cosmic event which destroyed the Martian atmosphere and had tumultuous impact on Earth. Further, it suggests that major extinction-causing cataclysms occur cyclically about every 30 million years and have happened in relatively recent times.

Drawing on the ever-growing body of astronomical evidence, authors Graham Hancock, Robert Bauval and John Grigsby suggest that a large comet fragmented near Mars approx. 20,000 years ago, resulting in

massive strikes on the southern Martian regions that dislodged a huge chunk of the crust on the opposite side of the planet. Fragments apparently rained down on Earth in two waves—13,000 to 12,000 years ago, and 11,000 to 10,000 years ago—effectively ending the most recent ice age.

The remnant of the cometary explosion is believed to be the vast Taurid meteor shower, with its attendant asteroids and large bodies like Comet Encke, through which Earth passes twice a year. The authors note that periods of chaos and rapid climate change have occurred every 1,000 to 500 years since this explosion and have marked rapid declines of civilisations. They reopen the book on the Martian monuments controversy and draw comparisons between the destruction of possibly parallel civilisations on Mars and at Giza, Egypt.

Considering the evidence, how can we be complacent about the serious threat posed by the staggering number of Earth-crossing asteroids and comets that have the potential to create a Martian-scale disaster on Earth? We could be in for a very rough ride...

HOW PRAYER HEALS

by **Walter Weston**

Publisher: Hampton Roads, USA, 1998

ISBN: 1-57174-092-9 (319pp tpb)

Price: AUD\$26.95; NZD\$33.95; £10.99; NLGf n/a; USD\$12.95

Distributors: **Aust**—Gemcraft, tel (03) 9888 0111; **NZ**—Peaceful Living, tel (07) 571 8105; **UK**—Airlift Book Co., tel 0181 804 0400; **Europe**—Try NEXUS office; **USA**—Hampton Roads, tel (804) 296 2772, 1800 766 8009, fax (804) 296 5096; **Can**—Dempsey, tel (604) 708 1081

The body of scientific evidence demonstrating the healing power of prayer is increasing at an encouraging rate, as Dr Walter Weston describes in the third book in his 'healing prayer' series, *How Prayer Heals: A Scientific Approach*.

Dr Weston is a Methodist minister in the US and a staunch advocate and practitioner of the healing prayer, particularly using the spoken word, the group dynamic, the hands-on approach and a modicum of faith. He explains that the chief requirement to set up the correct healing frequency is for the healer to establish a compassionate healing intent for the patient that is preferably based on a loving connection with God (regardless of religion). However, he does concede that some successful healing techniques utilise an understanding of energy dynamics without recourse to prayer. In one scientific study involving many healers using a variety of modalities, all were shown to emanate healing energy at the frequency of 7.83



REVIEWS



BOOKS

Hz—the same as the Schumann resonance which pervades the Earth itself.

Orthodox medical practitioners are still catching up with the human energy field paradigm which considers the total being—physical, emotional, mental, spiritual. But the more they are exposed to the positive, holistic results reported from the intercession of directed, love-motivated prayer and touch, the more open-minded they'll be to incorporating this approach in their treatments. Weston's advice for the 'uninitiated' is based on sound principles, and his book is recommended even for hardened sceptics.

THE FBI FILES: The FBI's UFO Top Secrets Exposed

by Nicholas Redfern

Publisher: Simon & Schuster, UK, 1998

ISBN: 0-684-85148-2 (354pp tpb)

Price: AUD\$24.95; NZD\$29.95; £9.99;

NLGf n/a; USD\$16.00

Distributors: **Aust/UK/USA**—Simon & Schuster; **NZ**—MacMillan, tel (09) 415 6672; **Europe**—Try NEXUS office.

Having analysed nearly 3,000 pages of recently declassified FBI documents on the UFO phenomenon, author Nick Redfern (*A Covert Agenda*) has to conclude that the truth is still 'out there'. Yet these documents, spanning 1947 to the early 1990s, confirm that the FBI did (and no doubt still does) take an active interest in the phenomenon from the perspective of 'internal security'—albeit in competition with the military and other agencies who've had the upper hand. This is more 'X-Files' than the TV series, and who can guess at what's in the still-declassified FBI files, let alone in those



of the Air Force, Navy, CIA, NSA, etc.

Nick Redfern has pieced together a revealing history of agency and military reports, many describing craft and strange green fireballs sighted by reliable eyewitnesses including Air Force and civilian pilots and law officers. The documents in the early years reflect not only the enormous number of sightings across the USA, but FBI Director Hoover's paranoia about being left out of the official loop. They also speak of the FBI's uncertainty over whether the craft were Soviet in origin, were part of an ultra-top-secret US or ex-Nazi project, or were extraterrestrial. The latter explanation seemed to gain favour, and through the 1950s and '60s the FBI amassed substantial files on 'contactees' like George Adamski. The files show that the FBI's attention was later grabbed by related mysteries including the animal mutilation phenomenon, alien abductions, the mysterious MJ-12 group and the infamous Men in Black.

That these files have been released at all surely suggests that the public is being prepared for an official acknowledgement on the reality of UFOs and extraterrestrials.

THE PHOENIX SOLUTION

by Alan F. Alford

Publisher: Hodder & Stoughton, 1998

ISBN: 0-340-69614-1 (484pp hc)

Price: AUD\$49.95; NZD\$69.95; £18.99;

NLGf 78.00; USD\$40.00

Distributors: **Aust/NZ**—Hodder Headline; **UK**—Hodder & Stoughton; **Europe/USA**—Eridu Books, UK, tel +44 1543 370453

In attempting to unravel the mysteries of ancient Egypt, Alan Alford (*Gods of the New Millennium*) has stumbled upon compelling evidence suggesting that the mythology and religion of the Egyptians was based on knowledge of cosmic catastrophes; moreover, that the source of this knowledge was an advanced, pre-dynastic race who lived alongside the Nile tribes for a relatively short time and probably built the original Great Pyramid at least as early as the 5th millennium BC—earlier than the Sphinx and all the other pyramids, he contends.

Alford draws on the work of astronomer Tom Van Flandern who, in the late 1970s, first proposed his 'exploded planet' hypothesis to explain comet origins and the formation of asteroid belts in our solar system, and has identified catastrophic planetary explosions/collisions that occurred 250, 65 and 3.2 million years ago. Alford sees the key Egyptian myths concerning Osiris and Isis, Horus and Set, and other 'gods' as paralleling the 'cosmic battle in the heavens' between a transiting planet colliding with and/or destabilising other planets and moons



REVIEWS

in our solar system, causing 'fireballs' and 'floods' to rain down on Earth. Ancient Sumerian legends about Enki and Enlil and even Plato's Atlantis myth relate to the same cosmic events, he asserts.

So, who was this 'lost race' that passed on this cosmic knowledge to the Egyptians and Sumerians? According to Alford, not necessarily extraterrestrials but quite possibly a terrestrial intelligentsia who had invented the telescope. As for specifics, we're left in the dark. However, for records of these cosmic events to have been left for the pre-dynastic Egyptians to discover, surely at least one of these events happened not too long beforehand—by some accounts, as recently as around 12,500 years ago.

THE ASTHMA BREAKTHROUGH

by Henry Osiecki, BSc.

Publisher: BioEthics Press Ltd, Australia, New Zealand, 1998

ISBN: 1-875239-15-4 (142pp tpb)

Price: AUD\$24.95; NZD\$24.95; £12.50; NLGf n/a

Available: **Australia**—Bioethics Press, tel (07) 3352 5088; **New Zealand**—BioEthics Press, tel/fax (09) 376 0219; **UK/Europe**—NEXUS offices

The statistics demonstrate that the medical approach to dealing with asthma has failed dismally in effectively treating this condition in children and adults. For instance, one in ten Australians has asthma, with an average of one in four children affected, and similar statistics have been reported in New Zealand and the UK. So what's causing this? Is there something about our post-industrial society that is promoting this debilitating, recurring illness?

According to Australian nutritionist Henry Osiecki, far too much emphasis has been placed on temporary alleviation of symptoms, rather than on understanding the condition and the causes of asthma. In *The Asthma Breakthrough*, Osiecki maintains that asthma is the result of complex biochemical processes and does not begin and end solely with the lungs. So, to deal with the problem, it is essential to promote general physical health but with a special focus on boosting the immune system and combating allergic reactions. Often this means avoiding substances which have immune-suppressing effects—anything from chemicals and pesticides to artificial colourings, chlorinated water and vaccines.

The contrast between the pharmaceutical preparations and the nutritional and alternative treatments that Osiecki presents is telling, and it's reprehensible that the public is so ill-informed about the options which have a high success rate in treating asthma.

Often the remedy is as simple as adopting different dietary guidelines, and Osiecki offers practical suggestions as well as recipes for promoting asthma-free living.

SECRET CITIES OF OLD SOUTH AMERICA

by Harold T. Wilkins

Publisher: Adventures Unlimited Press, USA, 1998 (first published 1952)

ISBN: 0-932813-55-0 (470pp tpb)

Price: AUD\$35.00; NZD\$ n/a; £15.50;

NLGf n/a; USD\$16.95 + p&h

Available: **Aust/NZ/UK/Europe**—NEXUS

offices (see details on page 2); **USA**—

Adventures Unlimited, PO Box 74, Kempton, IL 60946, tel (815) 253 6390

The US publisher Adventures Unlimited performs a worthy service in reprinting many hard-to-get books on lost civilisations that otherwise would become as lost as their subject matter.

This latest reprint, *Secret Cities of Old South America*, was first published in 1952 and was written by Harold T. Wilkins, a British historian who obviously enjoys poking fun at the establishment historical worldview, as he has done throughout these information-packed pages.

In this sequel to his 1946 book, *Mysteries of Ancient South America*, Wilkins presents evidence from mythology, from records of early Spanish expeditions and early 20th century European and American explorers, and from artefacts, inscriptions and ancient texts that suggests South America was once part of a vast empire known as Atlantis. The scope extends beyond South America, for Wilkins argues that the Atlantean sphere of influence took in Central America, the Caribbean, Ireland, Spain and Egypt before its final cataclysmic destruction.

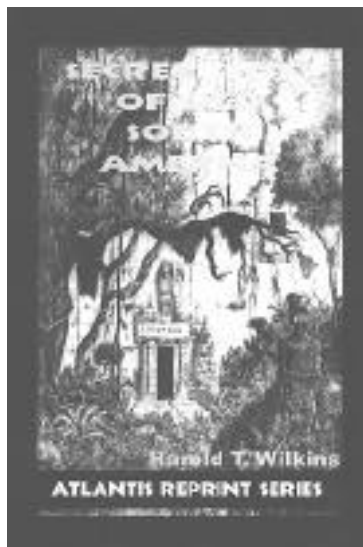

REVIEWS



Especially fascinating is the documentation about bearded white races existant in northern Brazil, in Peru and around Lake Titicaca—perhaps the descendants of pre-cataclysmic colonists. But also amazing are Wilkins' accounts of Amazonian women warriors, the secret lost city of Gran Paytiti in the Peruvian Andes, monstrous creatures whose existence was noted by local Indians as recently as last century, and the search for the gold of El Dorado. This is a wholly involving journey, and we can only wonder at what other treasures await discovery.

WORLD AGES

by Björn H. Hammarskog

Publisher: Pentland Press, USA, 1997

ISBN: 1-57197-057-6 (253pp tpb)

Price: £11.25; USD\$18.95 + \$3.50 p&h

Available: **UK**—Pentland Press, tel 01388 776555; **USA**—Pentland Press, tel (919) 782 0281, fax (919) 781 9042; Associated Publishers, tel 1800 327 5113

If you're only just catching on to the idea that civilisations have come and gone in a cosmic eye-twinkling many times on this planet but don't know where to direct your attention first, then start with a book that has a broad scope. This one, *World Ages*, considers the mythology and artefacts of ancient civilisations with regard to geological and astronomical evidence that points to cataclysmic events of greater and lesser degree affecting their progress. It's written by a Swedish consulting engineer, Björn Hammarskog, who, at 60, has finally taken to writing about his lifelong passion—the pursuit of humanity's age-old questions.

Skipping us through ancient pre-history, Hammarskog takes us into worlds where myths and legends could well be accounts of ancient catastrophes—as demonstrated, for example, in the variety of Creation and Flood myths recorded around the planet. Next, he conducts a whirlwind but fact-packed tour of ancient cultures, including Sumer, Babylon, Egypt, Crete, the Canary Islands, Scandinavia, India, China, the Pacific, Mesoamerica, the Andes and, of course, Atlantis—which he speculates existed in the Persian Gulf before major climatic change devastated the region.

Indeed, climatic change, from the catastrophic to the mildly drastic, has been occurring on a cyclic basis, affecting different parts of the Earth since time immemorial, and Hammarskog argues that it would be foolish to reject the evidence for cosmic events such as cometary impacts inducing such change in the past—or in the future.

VIDEOS

Reviewed by Duncan Roads

PROPHECY AND PREDICTION: Threat or Warning?

Producer: Film Montage, Australia, 1998
www.prophecyandprediction.com.au

Price: Telephone local contact for details (PAL & NTSC, 87mins)

Available: **Australia**—Film Montage, tel (03) 9699 2885; **NZ/UK/Eur**—NEXUS offices (see p. 2); **USA**—Matrix Institute, tel (603) 256 6759, 1800 628 7493

Most video documentaries on this subject often fall far short of the mark in terms of what people are interested in. Nearly all of us are sick and tired of the ambiguous Nostradamus, as though he were the only prophet out there.

This company did it right: they came to us for source material, and I am pleased to see a lot of it in this excellent film! As a result, you have Gordon-Michael Scallion, Tom Kaye, Mother Shipton, Malcolm Jagamara and others who normally never make it onto the screen.

The Channel 9 network broadcast a chopped-down version of this film on the night of 2 September, right across Australia, triggering much more work for Ronnie Burns, the main man on this show.

CD-ROM

Reviewed by Duncan Roads

THE UFO ANTHOLOGY Volume One

Producer: Dreamland Interactive, USA, 1998

Price: USD\$34.95

Platforms: Windows 95 (ugh); Windows NT, Windows 98, Mac and PowerMacs

Available: **USA**—Dreamland Interactive, tel +1 (818) 843 2945, 1888-UFO-WAVE, website, www.4dreamland.com

This is a really neat CD! Fully interactive, with literally hours of exploration into all facets of UFO research, including crop circles, implants and cattle mutilations. It contains video material featuring Bob Dean, Linda Moulton Howe, Dr Roger Leir, Jaime Maussan, Colin Andrews, astronaut Brian O'Leary and many more.

The producers have gone to considerable time and expense to get the best names in their fields onto this interactive CD. On top of these presentations, there are heaps of UFO pictures and film footage which will take you hours to get through.

(Readers of the Australian, US/Canada and UK/Europe editions will notice there is an advertisement for this excellent CD on the back or inside cover.)



REVIEWS

AUDIO

Reviewed by Richard Giles

WOMEN OF SPIRIT

by Various Artists

Producer: Dan Storper for Putumayo

World Music, USA, 1998 (60mins)

Distributors: **Australia**—MRA

Entertainment, tel (07) 3849 6020; **USA**—

Putumayo, tel (212) 625 1400

The US music company Putumayo has been a pioneer in the traditional music field, combining contemporary styles with national song. *Women of Spirit* is a collection of 13 original and extraordinary artists from 11 countries whose music redefines modern women's song. Brazilian, South African, Sudanese, Cameroon, Peruvian, French, Greek, Scottish and other women pour out their hearts and souls on this exceptional collection. Inspiring, uplifting, exciting music, guaranteed to grab you.

ENTER THE HEART

by Estéban

Producer: Robert Brock and Estéban for

Daystar Records, USA, 1998 (58mins)

Distributors: **USA**—Daystar Productions,

tel 1800 523 4059; Rock Bottom, tel (770)

448 8439, fax (770) 246 0820

Trained under classical guitarist Andres Segovia, Estéban is a renowned virtuoso acoustic guitarist with nine albums to his credit. *Enter the Heart* contains all original material, much of it dedicated to his various teachers. "Flamenco Wind" is dedicated to Vicenté Gomez, the amazing "Blue Lotus" to Paramahansa Yogananda, and "Avenida Concha Espiña" to Segovia. Estéban has a passionate and direct approach, and his mastery of many styles demonstrates a special versatility. With instrumental and percussive backing, he creates wonderful, emotional, feel-good music to be cherished.

THE JOURNEY

by Maryam Mursal

Producer: Simon Emmerson for Real

World Records, UK, 1998 (53mins)

Distributors: **Australia**—Festival Records,

UK—Real World Records; **USA**—Narada,

tel (414) 961 8350

In the 1970s, Maryam Mursal performed with Waaberi, a 300-strong Somali troupe of singers, dancers and musicians. When civil war split Somalia apart, the troupe broke up and Maryam fled across the desert with her family in 1991, finally settling in Denmark. *The Journey* is her second album, and with Peter Gabriel, Hossam Ramzy, former Waaberi members and Danish friends she has produced a funky, upbeat African

sound laced with her Somali roots. This is truly energetic, exciting and stirring music with a message.

SILENCIUM: SONGS OF THE SPIRIT

by The Silencium Ensemble

Producer: John Harle for Decca Records,

UK, 1997 (62mins)

Distributor: **Aus/NZ/UK/USA**—PolyGram

Three extraordinary sopranos working with the Academy of St Martin-in-the-Fields, the choir of Worcester Cathedral and the children of the New Brighton Primary School, produced by tenor John Harle with world music backing, makes this a stirring, uplifting album of choral and meditative music. *Silencium* lifts the sound from your speakers, taking it soaring to the rafters. Beautiful, experiential, spiritual music.

PILGRIMAGE

by The New London Consort

Producer: Simon Cloquet & Eric Calvi for

Point Music, UK, 1997 (53mins)

Distributor: **Aus/NZ/UK/USA**—Polygram

The melodies of 13th-century pilgrims, who travelled on religious quest to Santiago de Compostela, northwest Spain, are captured in this mediaeval/fusion music combined with chanting-style vocals from British soprano Catherine Bott. The specialness of choral music blended with an ambient, rhythmic flair, brings a modern quality to these hymns while retaining their sacred essence. Superbly ecstatic sounds.

• • • SPECIAL GIVEAWAY • • •

PolyGram Australia is offering NEXUS readers a chance to win a CD of either the *Pilgrimage* or *Silencium* albums. Write your name and address on the back of a plain envelope, address it to NEXUS MUSIC GIVEAWAY at PO Box 30, Mapleton, Old 4560, Australia, and post it so it arrives by Thursday 15 October. The first 10 envelopes drawn will receive a free copy of one of these two albums.

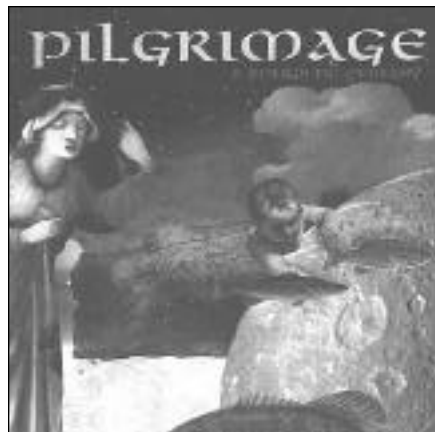

Continued from page 32

BANK OF LAVORO & IRAQGATE

In *Defrauding America*, Stich has an entire chapter on the background of the Bank of Lavoro and Iraqgate episode in recent history, i.e., the Persian Gulf War. Not only were Americans brainwashed by the government, CNN and other media to accept a totally bogus war in support of George Bush's so-called New World Order, but the Persian Gulf War was also used to test experimental vaccines on unknowing human guinea pigs—US and British Armed Forces personnel.

Stich includes the behind-the-scenes story of how the Bush Administration built up Saddam Hussein's regime with US loans, guaranteed by US taxpayers, to buy chemical and biological weapons. Result? The Persian Gulf War was a planned and programmed event guaranteed to make money for insiders.

CIA & DEA DRUG TRAFFICKING

Stich writes in a lengthy chapter in *Defrauding America*: "Many pilots have admitted to me during the past 40 years that they hauled drugs under the direction of the CIA, DEA [Drug Enforcement

Administration] and the military...

"The CIA-engineered Vietnam War provided the logistics making possible massive transportation of drugs from the Golden Triangle area of Asia into the United States. The CIA-engineered conflict in Nicaragua resulted in and made possible massive transportation of drugs from Central and South America into the US. These developed into multibillion-dollar-a-year profits for the CIA...

"It is no longer far-fetched to consider that the CIA may have deliberately generated these conflicts to develop its drug trafficking operations into the United States. Nor is it far-fetched to consider that these acts and consequences may be a part of a scheme to financially and morally destroy the United States."

OBSTRUCTION OF JUSTICE

In a chapter on US Federal Government corruption, Stich writes: "As stated in the 1978, 1980 and 1990 editions of *Unfriendly Skies*, and more so in the several editions of *Defrauding America*, at the epicentre of the corruption described within these pages are attorneys and officials in the US Department of Justice and federal judges. Without their criminal conduct, none of

these criminal activities could have been perpetrated or continued. The same applies to the mainstream media and to members of Congress, all of whom played key roles in the obstruction of justice."

SECRET ASSASSINATION TEAM

One of the most astounding, and sickening, revelations in *Defrauding America* is the exposure of the Secret Death Squad (SDS) or Experimental Assassination Team, officially listed by the CIA as MAC-SOGSDODV, or Military Assistance Command Strategic Operational Group Special Detachment, Department of Defense, Vietnam.

According to Stich, his informant Robert L. Freeman described to him an all-black assassination team, trained by the US military for an ultra-secret operation intended to destabilise Vietnam, Laos and Cambodia.

"Freeman was one of 45 blacks trained by the US Army, US Navy and the Central Intelligence Agency for the sole purpose of killing anyone, including US servicemen and advisers," writes Stich. "He described in great detail how his group was mentally

Continued on page 88

Continued from page 87

brainwashed, trained and armed, engaged in random and indiscriminate killings to destabilise the region and justify US intervention...

"Freeman was the head of a five-man assassination team ordered by the team's CIA handlers to kill anyone they encountered and leave evidence that another faction had done the killings. Freeman said that for several years his team went on a killing spree, sometimes wiping out an entire small village."

In *Defrauding America*, Stich includes top-secret US documents from 1963 and 1964 confirming the assassination of South Vietnam's President Ngo Dinh Diem by Freeman's team. In other words, the CIA sets up its puppet rulers, then murders them when it becomes expedient.

But there's more. Freeman also has hard evidence proving that his team was ordered by his CIA handlers to assassinate American POWs, and how his team carried out the orders.

"Those documents provided sufficient corroboration to make Freeman's descriptions believable," Stich reports. "Not that the assassination of American GIs ordered

by Washington were the biggest crimes ever inflicted upon Americans, but these were crimes that the average person could understand."

REPEAL OF THE US NATIONAL SECURITY ACT

As far as the US is concerned, the National Security Act of 1947 can be considered the root of evil described in Stich's books. It continues to provide an impenetrable shield for the arrogant abuse of power by government officials—namely the National Security Council, which operates under questionable constitutionality, as well as the so-called 'intelligence' agencies like the CIA, NSA and NRO.

These agencies' Cold War *raison d'être* has disappeared into the black hole of the phoney ideological battle known as the 'capitalism vs communism' scam. Now they remain as the last refuge of criminals and corrupt officials whose illegal practices continue under the guise of so-called national security.

Like the old-guard Soviet *nomenclatura* and its attendant *apparatchiks*, these agencies and the faceless bureaucrats who run them have garnered enormous power—most likely due to the cash flow from the

massive drug trafficking over the last 50 years.

And so it goes. Rodney Stich's life work and his books, especially *Defrauding America* (subtitled "An Encyclopedia of Secret Operations by the CIA, DEA and Other Covert Agencies"), are demonstration that the US National Security Act of 1947 must be repealed. Why? Because the secrecy, amorality and degeneracy spawned by the Act has changed the character of not only the United States but the world at large. Worst of all, it has brought about an institutionalised corruption and depravity in America that parallels nothing but the final days of the Roman Empire.

GRASSROOTS GROUPS & PUBLIC AWARENESS

What Rodney Stich has documented—criminal behaviour by public officials entrusted with government—can no longer be tolerated. Brave individuals have spoken out against this corruption and continue to expose the treacherous conduct of those who have betrayed public trust.

Like Amnesty International which works to release political prisoners in repressive regimes, there ought to be locally based grassroots groups for expanding public

Spooks, Whistleblowers and Fall Guys

awareness of government crimes, cover-ups and corruption. How about Whistleblowers International?

Now there's no other choice. It's up to us. You know we got to run the hoodoo out of town.

Bibliography

- Bucchi, Kenneth C., *CIA: Cocaine In America* (1994), SPI Books, 136 West 22nd Street, New York 10011, NY, USA, tel 212 633 2022.
- Castillo, Celerino and Dave Harmon, *Powderburns: Cocaine, Contras and the Drug War* (1994), Mosaic Press, 85 River Rock Drive #202, Buffalo, NY 14207, USA.
- Constantine, Alex, *Virtual Government: CIA Mind Control Operations in America* (1997), Feral House, 2532 Lincoln Blvd #359, Venice, CA 90291, USA.
- Eddy, Paul with Hugo Sabodal and Sara Walden, *The Cocaine Wars*, Bantam Books, New York.
- Fletcher, Bob, *Drugs & US Government Agencies* (video, US\$25); *Weather Control as a Weapon* (video, US\$25); *Exotic Weapons of Mass Control* (video, US\$38), World News Insight, 10061 Riverside Drive, #801, N. Hollywood, CA 91602, USA, tel 800 729 4131.
- Goddard, Donald and Lester K. Coleman, *Trail of the Octopus: From Beirut to Lockerbie—Inside the DIA*, Penguin Books, 1994 (unavailable in USA).
- Gritz, James "Bo", *Called To Serve* (1991), CPA, c/o HC 11, Box 307, Kamiah, Idaho 83536, USA.
- Gunderson, Ted, *Drug Smuggling*, published by Ted Gunderson, PO Box 18000-259, Las Vegas, Nevada 89114, USA, tel 702 650 5676, <www.net5000.com/gunderson/>.
- Hougan, Jim, *Spooks: The Haunting of America—The Private Use of Secret Agents*, William Morrow & Co., New York, 1978.
- Kruger, Henrik, *The Great Heroin Coup: Drugs Intelligence and International Fascism* (1980), South End Press, Box 68, Astor Station, Boston, MA 02123, USA.
- Kwitny, Jonathan, *The Crimes of Patriots: A True Tale of Dope, Dirty Money and the CIA*, Simon & Schuster Inc., New York, 1987.
- Levine, Michael, *The Big White Lie: The CIA and the Cocaine Crack Epidemic* (1993), Thunder's Mouth Press, 632 Broadway, 7th Floor, New York, NY 10012, USA.
- Lyne, William, *Space Aliens from the Pentagon* (1995, 2nd ed.), Creatopia Productions, Lamy, New Mexico 87540, USA, tel 505 466 3022.
- McCoy, Alfred W., *The Politics of Heroin: CIA Complicity in the Global Drug Trade* (1991), Lawrence Hill Books (imprint of Chicago Review Press, Inc.), 814 N. Franklin Street, Chicago, IL 60610, USA.
- Reed, Terry and John Cummings, *Compromised: Clinton, Bush and the CIA—How the Presidency was Co-opted by the CIA* (1994), SPI Books, 136 West 22nd Street, New York, NY 10011, USA, tel 212 633 2022.
- Ruppert, Michael C. (ed.), *From the Wilderness*, newsletter, available from 14358 Magnolia #313, Sherman Oaks, CA 91423, USA, website <www.copvcia.com> (US\$25).
- Stich, Rodney and T. Conan Russell, *Disavow—A CIA Saga of Betrayal*, Diablo Western Press, California, 1995.
- Stich, Rodney, *Unfriendly Skies—History of Corruption and Air Disasters*, Diablo Western Press, California, 1978, 1980, 1990 (3rd edition).
- Stich, Rodney, *Defrauding America: Encyclopedia of Secret Operations by the CIA, DEA and Other Covert Agencies* (1998, 3rd ed.), Diablo Western Press, PO Box 5, Alamo, CA 94507, USA, tel 1800 247 7389, website <www.defraudingamerica.com>.
- Sutton, Antony C., *America's Secret Establishment: An Introduction to the Order of Skull and Bones* (1986), Liberty House Press, 1517 14th St #216C, Billings, Montana 59102, USA.
- Tatum, Gene "Chip", *The Tatum Chronicles* (1996), PO Box 895082, Leesburg, FL 34789, USA, tel 800 201 7892, website <www.aci.net/kalliste/black ops>.
- Thomas, Kenn and Jim Keith, *The Octopus: Secret Government and the Death of Danny Casolaro*, Feral House, California, 1997.

About the Author:

Uri Dowbenko is a writer and syndicated columnist. His "alt.media" column is an entertaining and informative critique of current movies, books and pop culture with a social and political commentary. Samples of the column can be obtained from: "alt.media", PO Box 43, Pray, Montana 59065, USA; email <u.dowbenko@mailcity.com>.

Alien Healings: The Medical Evidence

Continued from page 75

found that his liver had been reduced to a normal size."

Another case which could easily have been included is that of Fred White of Durham, England, who was diagnosed with a hole in his heart—until he was cured by an alien while convalescing in hospital. One astonished doctor told White: "Your lung is completely inflated. The hole you had in there is healed. We've never seen anything like it."

Still another incredible cure of a heart defect occurred to an anonymous man from southern California. His doctors told him: "This is amazing. It looks like something has been somehow holding this defect together, but we can't figure out what it is."

Yet another well-known, inexplicable case was a cure of sterility which happened to former British Police officer Alan Godfrey. His doctor told him: "I don't know how it happened. Your condition has been completely reversed. The test shows you're fertile, back to normal."

More cases could be listed, complete with doctors' statements and other supporting evidence. With over a hundred cases

on record, there simply isn't the space to do so in an article of this size, but the proof is there for those who are willing to look.

Nevertheless, UFO investigators are always searching for the one case that will absolutely blow away all the sceptics with a flood of physical evidence, and this case has yet to come—otherwise the existence of UFOs would be universally accepted. Still, the sheer number of cases is educating virtually everyone to the possible existence of extraterrestrials. Today, ufology is being studied within multiple scientific disciplines including astrophysics and psychology. We have had congressional conferences, countless television programs and film documentaries, endless publications of all types.

Whether we like it or not, UFOs are here to stay. It remains in our own best interests to learn all we can about them. And if these ETs continue to visit our planet, it is only a matter of time before conclusive evidence is obtained. The more knowledge we can gather about them, the better prepared we will be. When this conclusive evidence is finally obtained, it will potentially change the world and the way we view our place in the Universe. The future

of ufology promises to be very exciting indeed.

Note: This article was adapted from the book *UFO Healings: True Accounts of People Healed by Extraterrestrials* (Wild Flower Press, 1996, ISBN 0-926524-33-X, 186pp, tpb). To order: in the USA contact Blue Water Publishing/Twigg Company, PO Box 2875, Rapid City, SD 57709, tel (605) 341 0020, 1800 366 0264, fax (605) 341 0020 (USD\$13.95 + \$4.00 p&h in USA, \$6.20 foreign); in the UK, contact Counter Culture, tel 01823 698895 (£9.95; limited stocks).

About the Author:

Preston Dennett has a BA in English from California State University of Northridge. He is a field investigator for the Mutual UFO Network and has been involved with organisations such as Citizens Against UFO Secrecy. He has had more than 50 UFO-related articles published since 1986 and has several books to his credit, including *UFO Healings* and *One in Forty: The UFO Epidemic* (1995). He lectures across the US on the UFO subject and lives in southern California.